

# SJT series

---

## METAL EXPANSION JOINT

S J T

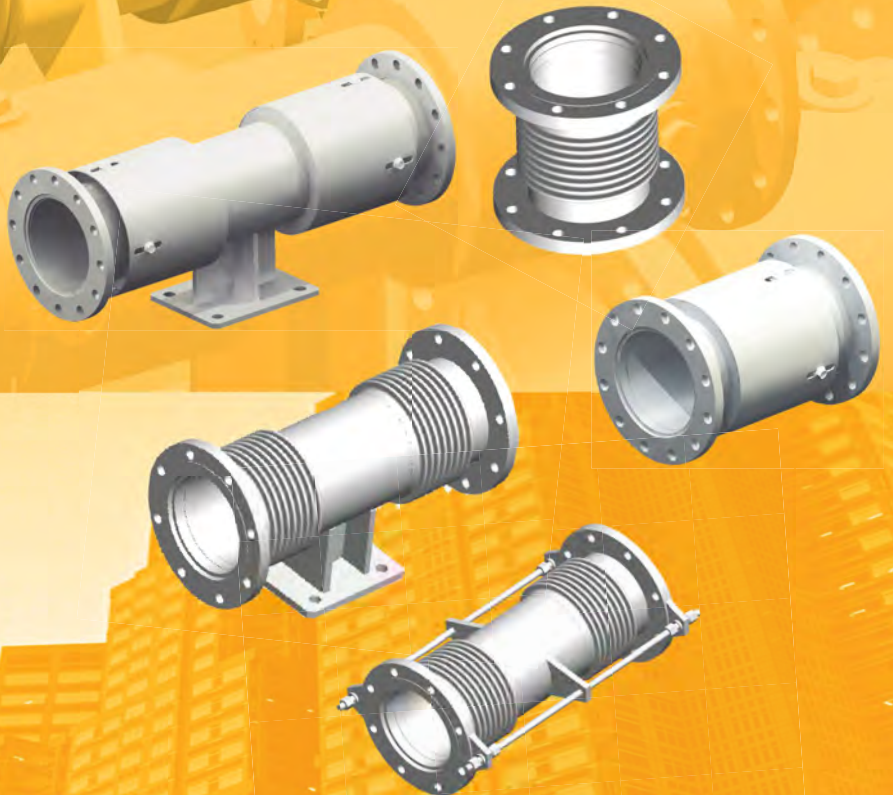

# SJT series

## METAL EXPANSION JOINT

### FEATURES

- Bellow Expansion Joints are employed in piping systems to absorb differential thermal expansion while containing the system pressure.
- Size is available from 25A (1") to 4000A (160").
- Typical working pressure varies from full vacuum to 1000 psig (66 bar) and temperature from -420°F (-215°C) to 1800°F (982°C) that refer from EJMA Organization.
- Standard design of movement and material maximizes the productivity while the custom design maximizes the suitability for special applications.
- Computer designed bellows element complies with EJMA criteria.
- All products are tested before delivery according to relevant code or ISO quality control system.

### APPLICATION

- Bellows type metal Expansion Joints are successfully utilized in refineries, chemical plants, fossil and nuclear power systems, heating and cooling system, and cryogenic plants.

### DEFINITION & TYPE OF EXPANSION JOINT

*EXPANSION JOINT* is any device containing one or more bellows used to absorb dimensional changes, such as those caused by thermal expansion or contraction of a pipeline, duct or vessel.

#### SINGLE EXPANSION JOINT

The simplest form of Expansion Joint, of single bellows construction, for the purpose of absorbing any combination of the three basic movements of the pipe section in which it is installed.

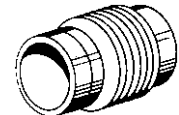

#### DOUBLE EXPANSION JOINT

A double Expansion Joint consists of two bellows joined by a common connector which is anchored to some rigid part of the installation by means of an anchor base. The anchor base may be attached to the common connector either at installation or at time of manufacture. Each bellows acts as a single Expansion Joint and absorbs the movement of the pipe section in which it is installed independently of the other bellows. Double Expansion Joints should not be confused with universal Expansion Joints.

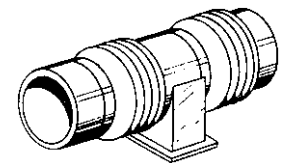

#### UNIVERSAL EXPANSION JOINT

A universal Expansion Joint is one containing two bellows joined by a common connector for the purpose of absorbing any combination of the three basic movements: axial movement, lateral deflection and angular rotation. Universal Expansion Joints are usually furnished with control rods to distribute the movement between the two bellows of the Expansion Joint and stabilize the common connector. This definition does not imply that only a universal Expansion Joint can absorb combined movement.

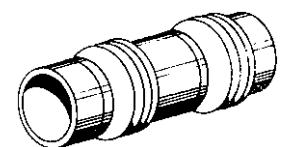

**UNIVERSAL TIED EXPANSION JOINT**

The tied universal Expansion Joints are used when it is necessary for the assembly to eliminate pressure thrust forces from the piping system. In this case the Expansion Joint will absorb lateral movement and will not absorb any axial movement external to the tied length.

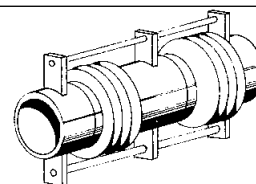

**SWING EXPANSION JOINT**

A swing Expansion Joint is one containing two bellows joined by a common connector designed to absorb lateral deflection and/or angular rotation in one plane. Pressure thrust and extraneous forces are restrained by the use of a pair of swing bars, each of which is pinned to the Expansion Joint ends.

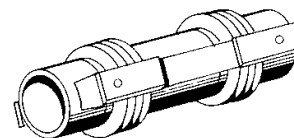

**HINGED EXPANSION JOINT**

A hinged Expansion Joint contains one bellows and is designed to permit angular rotation in one plane only by the use of a pair of pins through hinge plates attached to the Expansion Joint ends. The hinges and hinge pins must be designed to restrain the thrust of the Expansion Joint due to internal pressure and extraneous forces, where applicable. Hinged Expansion Joints should be used in sets of two or three to function properly.

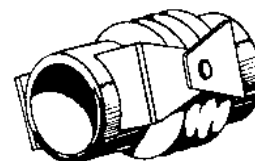

**GIMBAL EXPANSION JOINT**

A gimbal Expansion Joint is designed to permit angular rotation in any plane by the use of two pairs of hinges affixed to a common floating gimbal ring. The gimbal ring, hinges and pins must be designed to restrain the thrust of the Expansion Joint due to internal pressure and extraneous forces, where applicable.

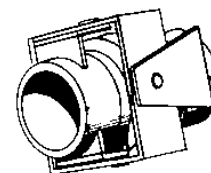

**PRESSURE BALANCED EXPANSION JOINT**

A pressure balanced Expansion Joint is designed to absorb axial movement and/or lateral deflection while restraining the pressure thrust by means of tie devices interconnecting the flow bellows with an opposed bellows also subjected to line pressure.

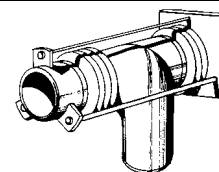

**IN-LINE PRESSURE BALANCED EXPANSION JOINT**

An in-line pressure balanced Expansion Joint is designed to absorb axial movement and/or lateral deflection while restraining the pressure thrust by means of tie devices interconnecting the line bellows with outboard compensating bellows also subjected to line pressure. Each bellows set is designed to absorb the axial movement and usually the line bellows will absorb the lateral deflection. This type of Expansion Joint is used in a straight run of piping.

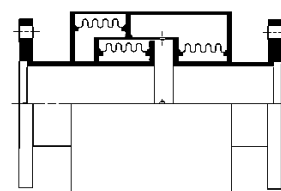

**EXTERNAL PRESSURIZED EXPANSION JOINT**

The external pressurized Expansion Joint is designed so that the pressure is external to the bellows whilst the inside is at atmospheric pressure and it has many convolutions to allow a large amount of axial movement. But under external pressure the bellows will retain its shape completely stable. Besides external pressurized bellows is protected from external damage by a heavy wall shroud and is isolated from flow impingement by an internal sleeve.

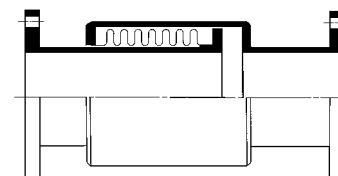

**EXPANSION JOINT WITH REINFORCING RING**

Devices used on some expansion joints fitting snugly in the roots of the convolutions. The primary purpose of these devices is to reinforce the bellows against internal pressure. Equalizing rings are made of cast iron, steel, stainless steel or other suitable alloys and are approximately "T" shaped in cross section. Reinforcing or roots rings are fabricated from tubing or solid round bars of carbon steel, stainless steel or other suitable alloys.

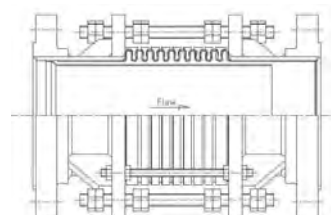

## MOTION

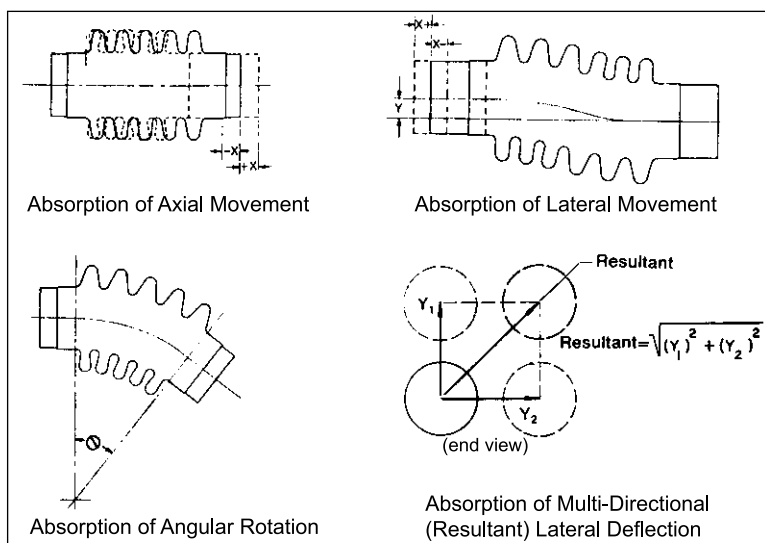

**Note :** Expansion Joint is not suitable for torsion or twisting movement, because such movement produces extremely high shear stresses in the bellows.

## SYSTEM PREPARATION

### 1) Simplify the system

Survey piping system and major equipment such as turbines, pumps, compressors, fan, etc. Check the length of piping which will expand to the system.

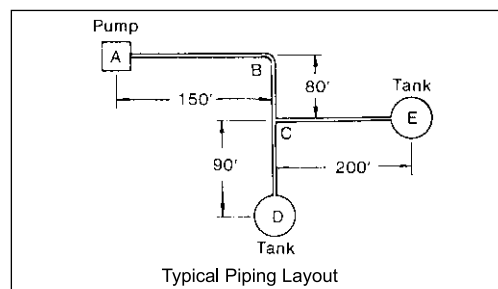

### 2) Calculating thermal growth

Determining thermal movement.

$\beta\Delta t$  (Unit : mm)

Temperature changes °C	Carbon Steel SGP, STPG, STPT, STPY, STPA22 less than 3CrMo	Alloy Steel 5 CrMo to 9 CrMo	Austenitic Stainless Steel 18Cr8Ni	Copper (CuZn)	Aluminium
-198	-1.782	-1.675	-2.905	-2.922	-3.530
-180	-1.651	-1.553	-2.668	-2.675	-3.267
-160	-1.496	-1.410	-2.398	-2.397	-2.965
-140	-1.334	-1.259	-2.122	-2.111	-2.646
-120	-1.165	-1.100	-1.840	-1.824	-2.312
-100	-0.991	-0.937	-1.549	-1.532	-1.965
-80	-0.808	-0.762	-1.254	-1.249	-1.608
-60	-0.617	-0.581	-0.953	-0.954	-1.234
-40	-0.419	-0.394	-0.642	-0.647	-0.839
-20	-0.212	-0.200	-0.323	-0.327	-0.426
0	0.000	0.000	0.000	0.000	0.000
20	0.218	0.206	0.328	0.336	0.441
40	0.442	0.418	0.660	0.679	0.894
60	0.673	0.637	0.997	1.032	1.363
80	0.909	0.862	1.338	1.394	1.846
100	1.153	1.091	1.684	1.762	2.332
120	1.400	1.321	2.032	2.124	2.832
140	1.653	1.554	2.381	2.510	3.333
160	1.917	1.792	2.734	2.894	3.843
180	2.178	2.034	3.091	3.280	4.361
200	2.448	2.278	3.450	3.676	4.886
220	2.724	2.528	3.810	4.077	5.421
240	3.002	2.784	4.174	4.486	5.959
260	3.286	3.042	4.540	4.901	6.505
280	3.576	3.304	4.911	5.317	7.062
300	3.870	3.573	5.286	5.742	7.626
320	4.173	3.843	5.661	6.170	8.179

$$\Delta X = L \times \beta\Delta t$$

$\Delta X$  = Axial Movement (mm)

L = Length of piping (metre)

$\beta\Delta t$  = Thermal Expansion by one metre (mm/m)

**3) Pipe anchors and forces**

Must be designed to withstand all of the forces acting upon them. Two significant forces which are unique of Expansion Joint system are spring force and pressure thrust force.

● **Main Anchors**

Must be designed to withstand the forces and movements imposed upon it by each of the pipe sections to which it is installed. In systems containing Expansion Joint , main anchors are installed at any of the following locations.

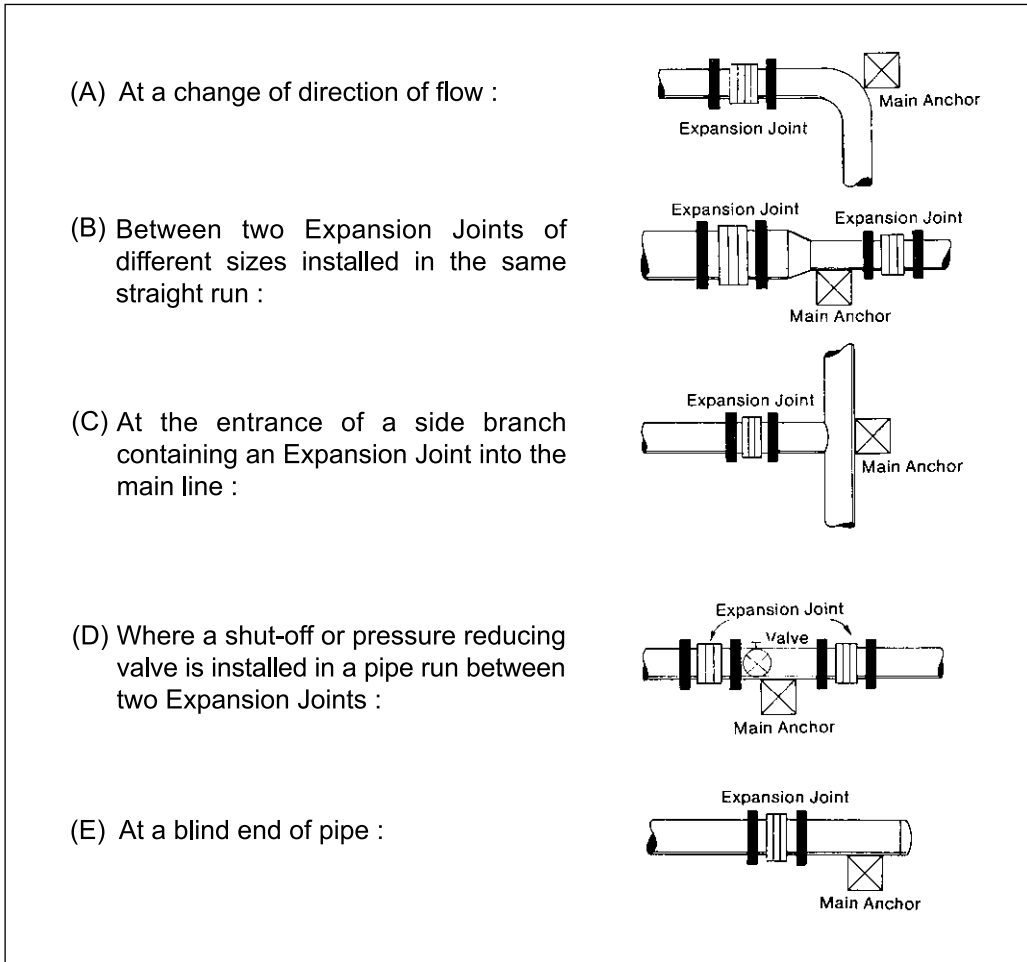

● **Intermediate Anchors**

are not intended to withstand pressure thrust force, but it withstands all of the non-pressure forces such as spring forces and frictional forces in pressure balanced or double Expansion Joint.

● **Pipe Guide and Support**

Pipe Guides are necessary to insure proper alignment of movement to the Expansion Joint and to prevent buckling of the line.

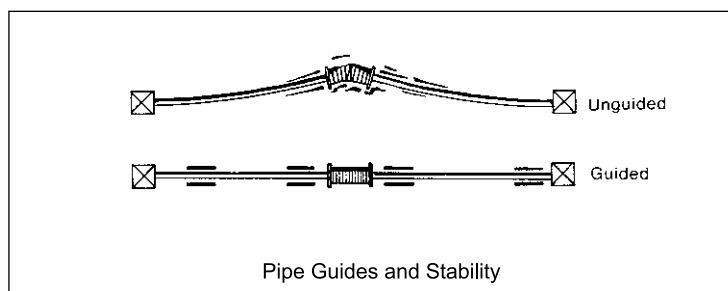

● **Pipe Guide Application**

Generally recommended that the Expansion Joint is located near an anchor, and any other guides should determine the position like below figure.

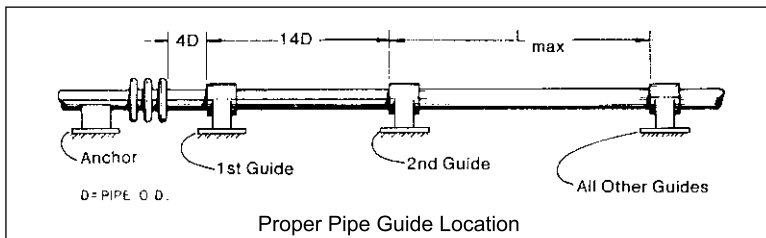

D = Nominal diameter of pipe

L<sub>max</sub> = see below graph

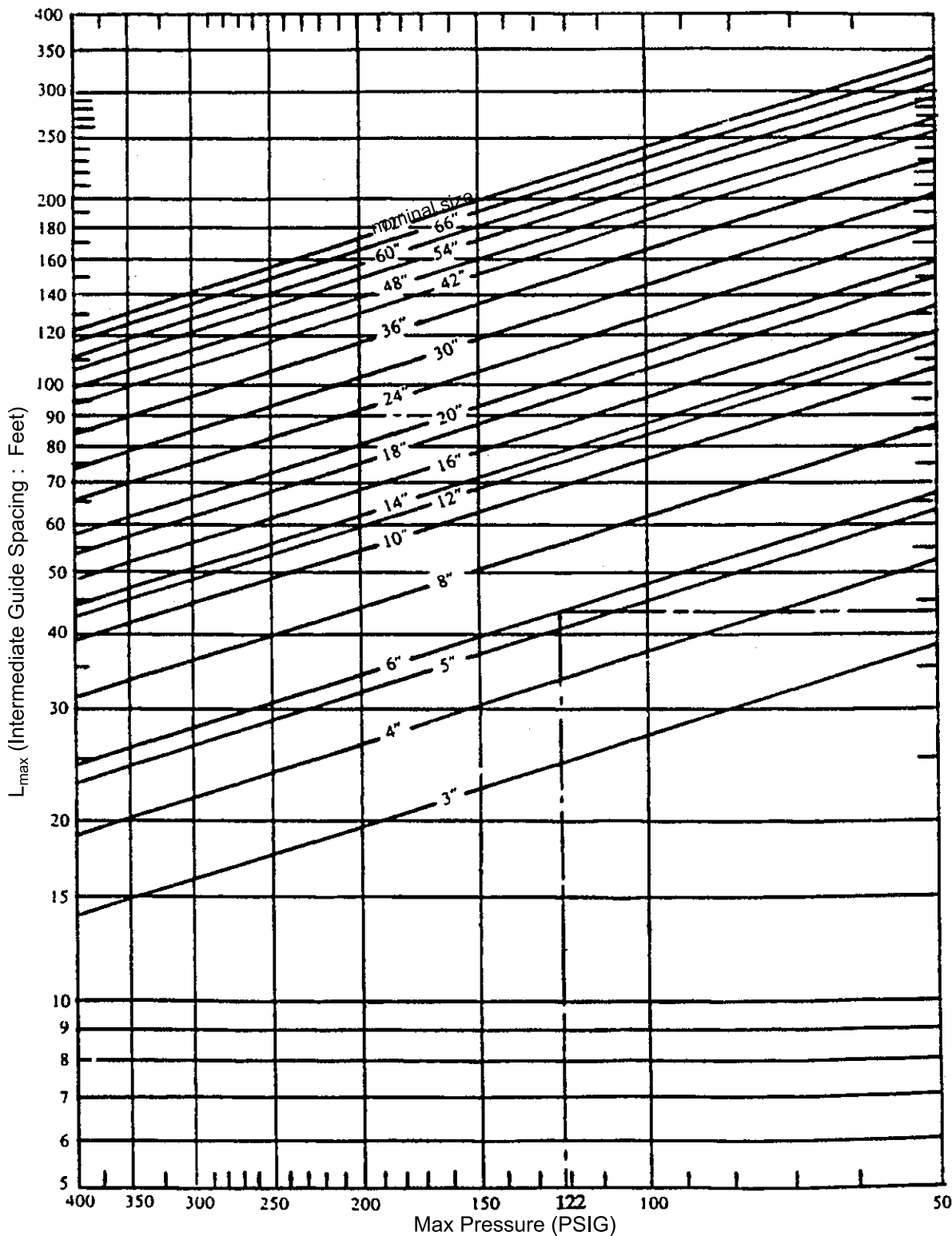

43

## Guide for storage and installation

1)  Inspect damage such as dent, burr, broken, etc.

2) Store in the clean and dry area. Don't expose the joint in hazardous or corrosive environment.

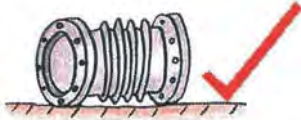

3) Never use chains or other devices directly on the bellows.



4) Don't use cleaning agents which contain chlorides.



5) Don't drop or strike Expansion Joint and beware bellows when you have welding process.



6) Don't force or rotate one end of an Expansion Joint for alignment of bolt holes because torsions may damage the joint.



7) Check working pressure & working temperature do not exceed the limited.

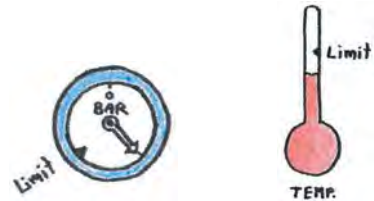

8) Check the corrective of flow direction (see arrow mark)



with fluid flow.

9) Check for adequate anchor and guide support for the system.

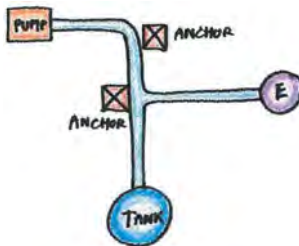

10) Insert gasket between Expansion Joint and counter flange.

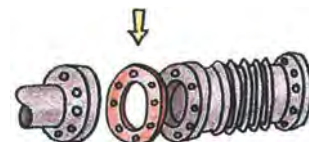

11) Remove shipping bar after installation completed.



**Note :** Don't use shipping bars to restrain the pressure thrust during testing.

## Installation Instruction

### Expansion Joint Installation

The bellows of an Expansion Joint is manufactured from relatively thin material in order to provide the flexibility needed to absorb the specified movement. The life of the Expansion Joint can be shortened if the unit is improperly handled and/or installed. This can arise from direct physical damage to the bellows through stresses imposed during installation, or by other factors. Therefore some basic instructions must be followed having safe and proper installation of Expansion Joints.

### Pipework system design

Tozen strongly recommends that you seek the advice of qualified Pipework engineer on your piping system and Expansion Joint selection. Pipework containing Expansion Joints requires careful anchoring and guiding for the Expansion Joint(s) to operate to their designed capacity.

### Pipe anchors

The function of a pipe anchor is to divide the pipeline into individual expanding sections. Because thermal growth cannot be restrained, it becomes the functions of the anchors to limit and control the amount of movement which Expansion Joints located between these anchors will absorb. Sometimes equipment such as turbines, pump, compressors, heat exchanger, etc. may possibly act as anchors.

### Pipe Guides

Correct alignment of the adjoining Pipework is essential in the proper functioning of an Expansion Joints. Pipe guides are necessary to ensure movement is directed onto the Expansion Joint and also to prevent buckling of the pipeline.

### Receiving Inspection

Upon receipt, identify and inspect the Expansion Joints for any damage that may have occurred in transit. We recommend that the Expansion Joints be stored in a safe area in its original packaging until ready for installation. Contact Tozen immediately if any repairs should be required.

### Installation Guidelines

- 1) Anchors, guides, and pipe supports must be installed in strict accordance with the piping system drawing. Any field variances from the planned installation may affect the proper functioning of the Expansion Joint.
- 2) No movement or stresses shall be imposed on Expansion Joint during installation. This may occur through pipe or flange bolt hole misalignment or due to mishandling. The pressure capacity, fatigue life, and stability of the bellow may be diminished, and unanticipated forces may be imposed on the adjacent pipework/or equipment.
- 3) Expansion Joints fitted with a flow liner shall be installed in accordance with the flow arrow given on the Expansion Joint.
- 4) Extreme care shall be taken during unloading and installation to prevent damage. In particular the bellows is readily prone to damage. Such damage may include dent, scores, arc strikes, and weld spatter, all of which may be detrimental to the proper functioning of the Expansion Joint. Protect the bellows with wet, chloride free, insulation blanket during welding installation.
- 5) Shipping bars painted yellow, or shipping rods, must be removed from the Expansion Joint once it is correctly installed, and prior to hydrostatic testing of the system. This will allow the Expansion Joint to move as designed.

### Warranty

Warranty is void if these instructions are not followed.



## Case of Installation & Piping System Forces Calculation

Case 1

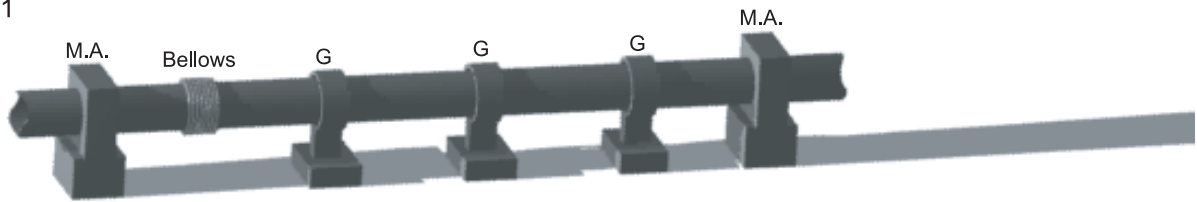

The basic form of single bellows Expansion Joint in a straight line piping between two Main Anchors (M.A.) with support Guides (G).

Case 2

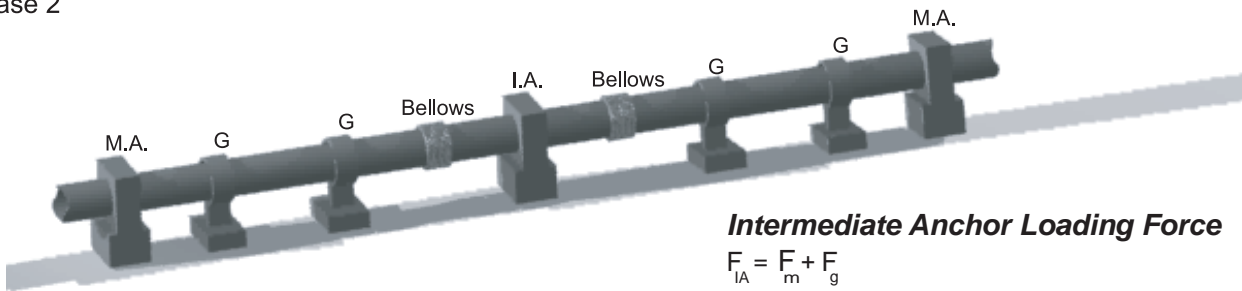

**Intermediate Anchor Loading Force**

$$F_{IA} = F_m + F_g$$

Universal or double bellow Expansion Joint in straight line piping between two Main Anchors and Intermediate Anchors (I.A.) at middle line with support Guides installed.

Case 3

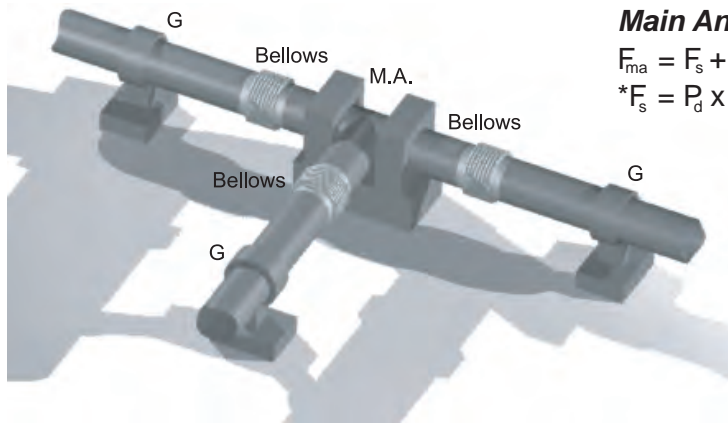

**Main Anchor Loading Force**

$$F_{ma} = F_s + F_m + F_g$$

$$*F_s = P_d \times A_e$$

Case of Installation : Expansion Joint at the entrance of a side branch piping.

Case 4

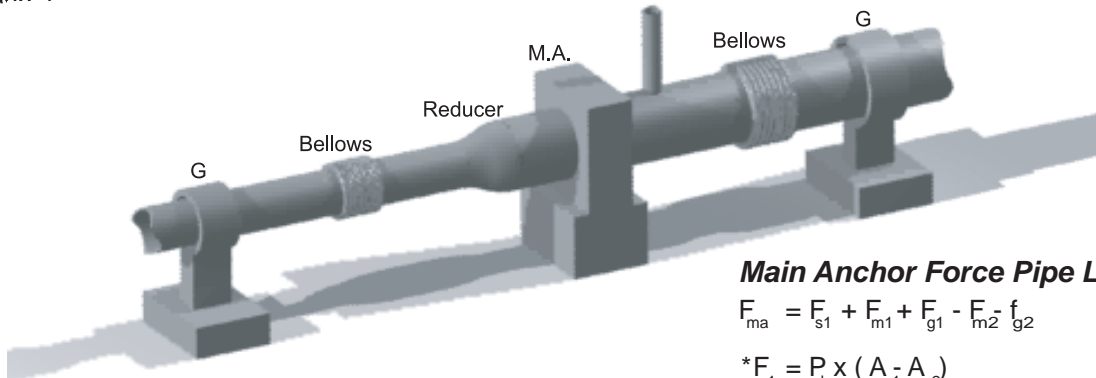

**Main Anchor Force Pipe Line Reduce**

$$F_{ma} = F_{s1} + F_{m1} + F_{g1} - F_{m2} - f_{g2}$$

$$*F_{s1} = P_d \times (A_{e1} - A_{e2})$$

Case of Installation : Expansion Joint between two pipes of different sizes in straight line.

The following system have no main anchor and have free area for displacement.

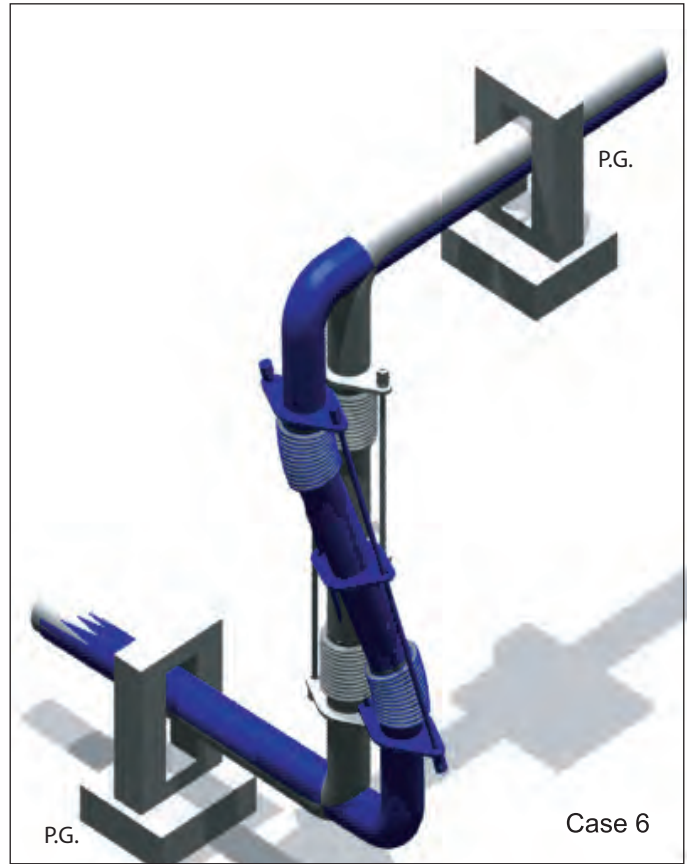
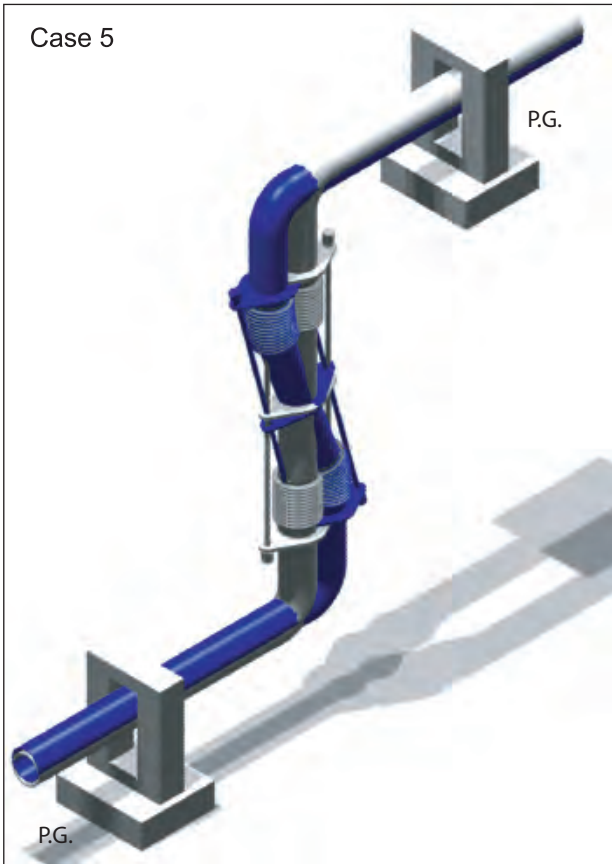

**Definitions**

- $F_{ma}$  = Main Anchor Force
- $F_{IA}$  = Intermediate Anchor Force
- $F_S$  = Force due to internal pressure
- $F_m$  = Force due to Joint deflection
- $F_{m1}$  = Force due to Joint deflection, large pipe section
- $F_{m2}$  = Force due to Joint deflection, small pipe section
- $F_g$  = Friction force of pipe guide
- $F_{g1}$  = Friction force of pipe guide, large pipe section
- $F_{g2}$  = Friction force of pipe guide, small pipe section

- $P_d$  = Design pressure
- $A_e$  = Effective area of Bellows
- $A_{e1}$  = Effective area of Bellows, large pipe section
- $A_{e2}$  = Effective area of Bellows, small pipe section
- I.A. = Intermediate Anchor
- M.A. = Main Anchor
- P.G. = Planar Pipe Guide
- G = Pipe Guide

# Expansion Joint Inquiry Sheet



Customer					Date:	
Project					Prepared by:	
Inquiry For	Cost	Tag Number:				
	Drawing	Quantity:	Set(s)	Set(s)	Set(s)	Set(s)
	Revision	Expansion Joint Type				
Dimensions		Size				
		Overall Length	mm.	mm.	mm.	mm.
Materials		Bellows				
		Liner (Inner sleeve)				
		Cover				
End Connections	Pipe	OD	mm.	mm.	mm.	mm.
		Thickness	mm.	mm.	mm.	mm.
	Flange	Liner Material				
		Flange Standard Material				
Pressure		Design	Bar	Bar	Bar	Bar
		Operating	Bar	Bar	Bar	Bar
		Test	Bar	Bar	Bar	Bar
Temperature		Design	°C	°C	°C	°C
		Operating	°C	°C	°C	°C
		Test	°C	°C	°C	°C
Media		Media (Fluid)				
		Flow Velocity				
		Flow Direction				
Movements And Life Cycle	Design	Axial Extension	mm.	mm.	mm.	mm.
		Axial Compression	mm.	mm.	mm.	mm.
		Lateral	mm.	mm.	mm.	mm.
		Angular	°	°	°	°
		Number of Cycles				
	Operating	Axial Extension	mm.	mm.	mm.	mm.
		Axial Compression	mm.	mm.	mm.	mm.
		Lateral	mm.	mm.	mm.	mm.
		Angular	°	°	°	°
		Number of Cycles				
Maximum Spring Rates		Axial Spring Rate	N/mm	N/mm	N/mm	N/mm
		Lateral Spring Rate	N/mm	N/mm	N/mm	N/mm
		Angular Spring Rate	N/°	N/°	N/°	N/°
Control Unit Requirement	Tie Rod, Limit Rod, Shipping Rod, etc.					
Support Documents Requirement	Test Certificate, Material Certificate					
Other Requirement						

# Classification of STAINLESS STEEL EXPANSION JOINT

SJT -

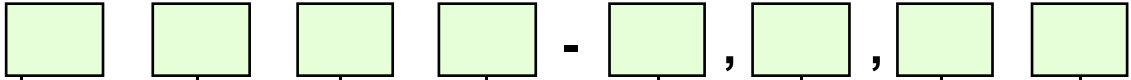

BELLOW	
1	Single
2	Double
0	Others

MATERIAL OF CONNECTION	
0	Mild Steel
1	All SUS304
2	SS400(Dry Part + SUS304 (Wet Part))
3	All SUS316
4	SS400(Dry Part + SUS316 (Wet Part))
5	Carbon Steel
6	SUS304(Dry Part + SUS316 (Wet Part))
S	User defined

STANDARD OF FLANGE	
1	JIS10K
2	JIS20K
3	ANSI150LB
4	ANSI300LB
5	PN10
6	PN16
7	PN25
S	User defined

TYPE OF FLANGE	
(none)	Both Ends Fixed Flanges
FL	Fixed x Loose Flanges
LL	Both Ends Loose Flanges
BB	Both Ends Pipe
FB	Fixed Flange x End Pipe
LB	Loose Flange x End Pipe
O	Others

COMBINATION	
1	Axial Free Type
2	Axial Covered Type
3	Axial Reinforced Type
4	External Pressurised Type
5	Hinged Type
6	Gimbal Type
7	Universal Type
8	Tied Type
9	Pressure Balanced Type
0	Others

MATERIAL OF BELLOWS	
(none)	SUS304
316	SUS316
316L	SUS316L
316Ti	SUS316Ti
---	Others (specify)

SPECIAL CASE	
(none)	with Shipping Rods
NS	No Inner Sleeve
LR	with Limit Rod
VS	Vanstone Type
NP	No Pipe
---	Others

# SJT1100

## STAINLESS STEEL EXPANSION JOINT

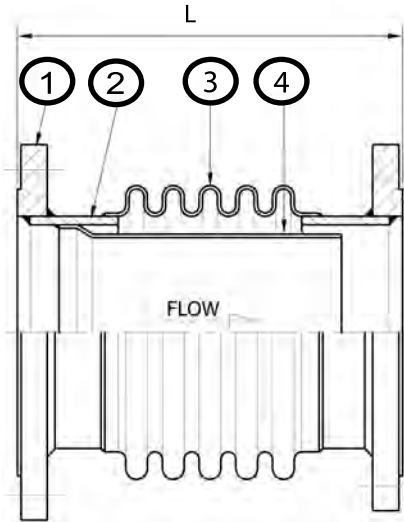
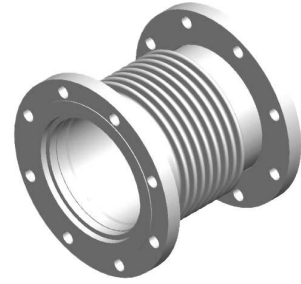

Item	Qty	Name	Standard Material
1	2	Flange	SS400
2	2	Short Pipe	CS
3	1	Bellows	SUS316L
4	1	Internal Sleeve	SUS316L

SJT-1101,1103,1105 10 bars (150 PSI)  
 SJT-1102,1104 20 bars (300 PSI)  
 SJT1106 16 bars (232 PSI)  
 SJT1107 25 bars (360 PSI)

<b>Design Working Pressure</b>	10-25 Bar (150-360 PSI)
<b>Design Working Temperature</b>	250°C
<b>Applicable Fluid</b>	Water, Hot Water, Oil, Steam, Gas, and Exhaust Air

- Please consult us for other material, temperature and movement designs
- Shipping devices (yellow sticker) must be removed prior to start-up or testing the system.

Size	Axial Movement (mm)	Axial Spring Rate (N/mm)	Effective Area (cm <sup>2</sup> )	SJT-1100		SJT-1100-BB		L(mm) of SJT-1100 Other Type			
				L (mm)	Weight (kg)	L (mm)	Weight (kg)	VS	NP	FL	LL
40A	25	68	25	250	4	250	1	150	145	245	245
50A	25	79	36	250	5	250	1	150	150	250	250
65A	35	87	51	250	8	250	2	200	200	260	265
80A	35	90	79	250	10	250	2	200	200	260	250
100A	35	105	131	275	14	275	4	220	200	280	285
125A	35	101	198	275	17	275	5	220	200	280	280
150A	35	136	265	300	21	300	7	220	200	305	305
200A	35	166	440	300	32	300	9	250	230	305	305
250A	35	169	679	350	43	350	13	300	270	355	355
300A	35	217	943	350	65	350	18	300	290	365	365
350A	35	225	1125	350	84	350	22	300	290	375	375
400A	35	337	1469	350	106	350	26	300	290	375	375
450A	35	344	1844	375	123	375	36	300	290	405	405
500A	35	377	2252	375	153	375	42	300	290	405	405
600A	35	602	3215	375	216	375	62	300	290	420	420

# SJT1200

## STAINLESS STEEL EXPANSION JOINT

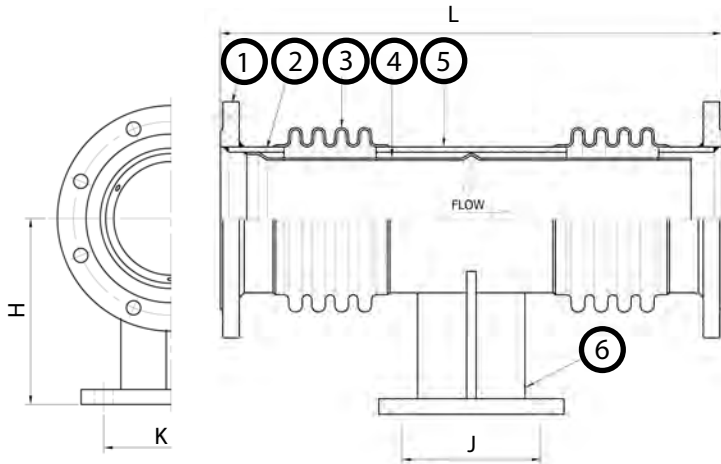

Item	Qty	Name	Standard Material
1	2	Flange	SS400
2	2	Short Pipe	CS
3	1	Bellows	SUS316L
4	1	Internal Sleeve	SUS316L
5	1	Middle Pipe	CS
6	1	Anchor Base	SS400

SJT-1201,1203,1205 10 bars (150 PSI)  
 SJT-1202,1204 20 bars (300 PSI)  
 SJT-1206 16 bars (232 PSI)  
 SJT-1207 25 bars (360 PSI)

<b>Design Working Pressure</b>	10-25 Bar (150-360 PSI)
<b>Design Working Temperature</b>	250°C
<b>Applicable Fluid</b>	Water, Hot Water, Oil, Steam, Gas, and Exhaust Air

- Please consult us for other material, temperature and movement designs
- Shipping devices (yellow sticker) must be removed prior to start-up or testing the system.

Size	H (mm)	J (mm)	K (mm)	Ød (mm)	Axial Movement (mm)	Axial Spring Rate (N/mm)	Effective Area (cm <sup>2</sup> )	SJT-1200		SJT-1200-BB	
								L (mm)	Weight (kg)	L (mm)	Weight (kg)
40A	120	100	70	12	50	68	25	450	6	450	3
50A	130	100	80	15	50	79	36	470	9	470	4
65A	140	120	100	15	70	87	51	570	13	570	7
80A	150	120	110	15	70	90	79	570	16	570	8
100A	170	120	130	19	70	105	131	570	21	570	11
125A	200	120	150	19	70	101	198	600	28	600	17
150A	220	160	180	23	70	136	265	650	36	650	23
200A	250	160	220	25	70	166	440	650	58	650	35
250A	300	180	280	27	70	169	679	750	80	750	50
300A	350	200	300	27	70	217	943	750	110	750	63
350A	450	250	350	33	70	225	1125	770	151	770	88
400A	500	300	400	33	70	337	1469	800	195	800	115
450A	550	350	450	39	70	344	1844	840	237	840	150
500A	600	400	500	39	70	377	2252	900	295	900	184
600A	650	450	550	45	70	602	3215	900	402	900	248

# SJT2100

## AXIAL COVERED TYPE SINGLE EXPANSION JOINT

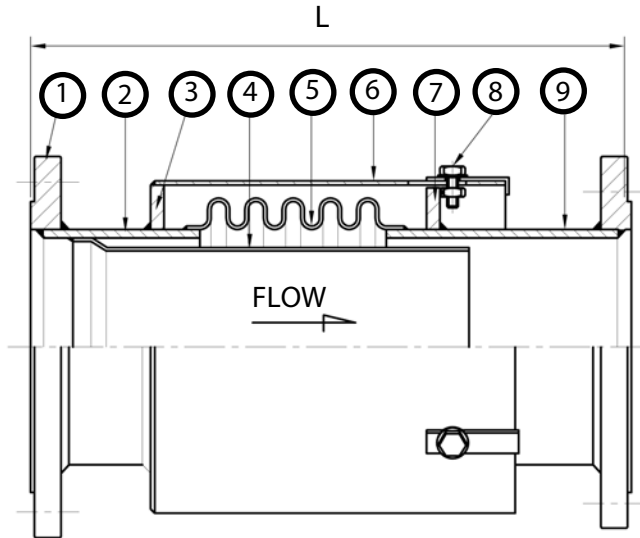
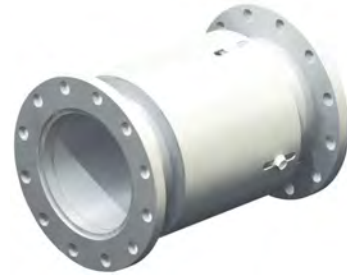

Item	Qty	Name	Standard Material
1	2	Flange	SS400
2	1	Short Pipe 1	CS
3	1	Neck Ring 1	SS400
4	1	Internal Sleeve	SUS316L
5	1	Bellow	SUS316L
6	1	Cover	SS400
7	1	Neck Ring 2	SS400
8	-	Shipping Bolt, Nut, Washer	SS400
9	1	Short Pipe 2	CS

<b>Design Working Pressure</b>	10-25 bars(150-360 PSI)
<b>Design Working Temperature</b>	250°C
<b>Applicable Fluid</b>	Water, Hot Water, Oil, Steam, Gas, and Exhaust Air

- Shipping devices (*yellow sticker*) must be removed prior to start-up or testing the system.
- Please consult us for other material, temperature and movement designs.
- SJT-2101,2103,2105 10 bars (150 PSI)  
 SJT-2102,2104 20 bars (300 PSI)  
 SJT-2106 16 bars (232 PSI)  
 SJT-2107 25 bars (360 PSI)

Size	Axial Movement (mm)	Axial Spring Rate (N/mm)	Effective Area (cm <sup>2</sup> )	SJT-2100		SJT-2100-BB	
				L (mm)	Weight (kg)	L (mm)	Weight (kg)
40A	25	68	25	365	5	365	2
50A	25	79	36	365	7	365	3
65A	35	87	51	415	12	415	5
80A	35	90	79	415	14	415	6
100A	35	105	131	415	20	415	9
125A	35	101	198	440	24	440	12
150A	35	136	265	440	30	440	15
200A	35	166	440	440	48	440	24
250A	35	169	679	465	64	465	33
300A	35	217	943	465	91	465	42
350A	35	225	1125	465	117	465	52
400A	35	337	1469	490	149	490	66
450A	35	344	1844	490	171	490	79
500A	35	377	2252	490	207	490	90
600A	35	602	3215	520	288	520	126

# SJT2200

## AXIAL COVERED TYPE DOUBLE EXPANSION JOINT

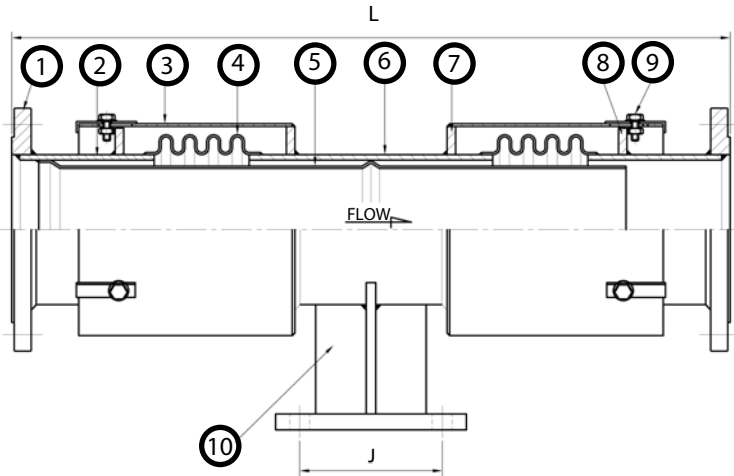

Item	Qty	Name	Standard Material
1	2	Flange	SS400
2	2	Short Pipe	CS
3	2	Cover	SS400
4	2	Bellows	SUS316L
5	1	Internal Sleeve	SUS316L
6	1	Middle Pipe	CS
7	2	Neck Ring 1	SS400
8	2	Neck Ring 2	SS400
9	-	Shipping Bolt, Nut, Washer	SS400
10	1	Anchor Base	SS400

<b>Design Working Pressure</b>	10-25 Bar (150-360 PSI)
<b>Design Working Temperature</b>	250°C
<b>Applicable Fluid</b>	Water, Hot Water, Oil, Steam, Gas, and Exhaust Air

- Shipping devices (*yellow sticker*) must be removed prior to start-up or testing the system.

- SJT-2201,2103,2105 10 bars (150 PSI)
- SJT-2202,2104 20 bars (300 PSI)
- SJT-2206 16 bars (232 PSI)
- SJT-2207 25 bars (360 PSI)

- Please consult us for other material, temperature and movement designs.

Size	H (mm)	J (mm)	K (mm)	Ød (mm)	Axial Movement (mm)	Axial Spring Rate (N/mm)	Effective Area (cm <sup>2</sup> )	SJT-2200		SJT-2200-BB	
								L (mm)	Weight (kg)	L (mm)	Weight (kg)
40A	120	100	70	12	50	68	25	680	8	680	6
50A	130	100	80	15	50	79	36	680	12	680	8
65A	140	120	100	15	70	87	51	780	19	780	12
80A	150	120	110	15	70	90	79	780	23	780	15
100A	170	120	130	19	70	105	131	880	33	880	22
125A	200	120	150	19	70	101	198	880	42	880	30
150A	220	160	180	23	70	136	265	930	54	930	39
200A	250	160	220	25	70	166	440	930	89	930	65
250A	300	180	280	27	70	169	679	980	120	980	89
300A	350	200	300	27	70	217	943	980	159	980	110
350A	450	250	350	33	70	225	1125	1030	216	1030	150
400A	500	300	400	33	70	337	1469	1030	270	1030	186
450A	550	350	450	39	70	344	1844	1080	329	1080	237
500A	600	400	500	39	70	377	2252	1080	388	1080	271
600A	650	450	550	45	70	602	3215	1200	524	1200	362



# SJT4100

## EXTERNAL PRESSURIZED EXPANSION JOINT

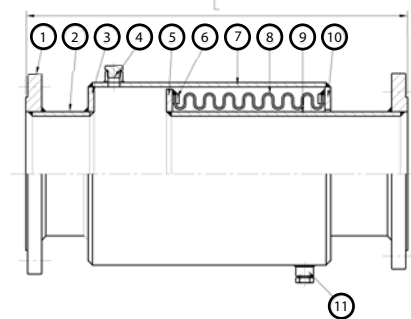

Item	Qty	Name	Standard Material
1	2	Flange	SS400
2	1	Short Pipe	CS
3	1	Band Ring	SS400
4	1	Purge Connection	CS
5	1	Guide Ring	SS400
6	4	Half Ring	SUS304
7	1	Cover Pipe	SS400
8	1	Stainless Steel Bellows	SUS316L
9	1	Inner Pipe	CS
10	1	Cap Ring	SS400
11	1	Drain	CS

<b>Design Working Pressure</b>	10-25 Bar (150-360 PSI)
<b>Design Working Temperature</b>	200°C
<b>Design Working Pressure</b>	10 Bar
<b>Applicable Fluid</b>	Water, Hot Water, Oil, Steam, Gas, and Exhaust Air

- Besides the large amount of axial movement, another special feature of external pressure balanced type expansion joint is the self-draining convolutions. It can prevent any the acumination of corrosive or solid particles from building up. Liquid media can 100% drains away from the drain connection, if needed,assists by the purging.
- SUS 304 bellows and pipe are available upon requested.
- Please consult us for other material, temperature and movement designs.

- SJT-4101,4103,4105 10 bars (150 PSI)  
SJT-4102,4104 20 bars (300 PSI)  
SJT-4106 16 bars (232 PSI)  
SJT-4107 25 bars (360 PSI)
- For steam application, it is advised using steam trap with the drain connection which eliminates the possibility of any condensate liquid "flashing" to vapor during startups.
- Shipping devices (*yellow sticker*) must be removed prior to start-up or testing the system.

Size	Axial Movement (mm)	Axial Spring Rate (N/mm)	Effective Area (cm <sup>2</sup> )	L (mm)	Weight (kg)
25A	-50	28	27	475	7
32A	-50	28	27	475	8
40A	-50	28	27	475	9
50A	-50	31	53	500	13
65A	-50	28	78	550	21
80A	-75	33	86	750	31
100A	-100	28	162	800	54
125A	-100	45	232	800	60
150A	-100	50	302	850	84
200A	-100	57	481	850	114
250A	-100	68	714	850	141
300A	-100	98	1001	875	196
350A	-100	98	1190	875	269
400A	-100	118	1517	875	342

# SJT 7200

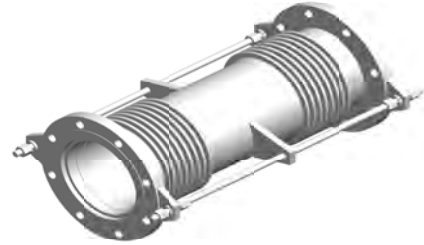

**UNIVERSAL TYPE DOUBLE EXPANSION JOINT WITH LIMIT RODS**  
 Classical type of double bellows construction, for large amount of axial and lateral movement.

## Structure

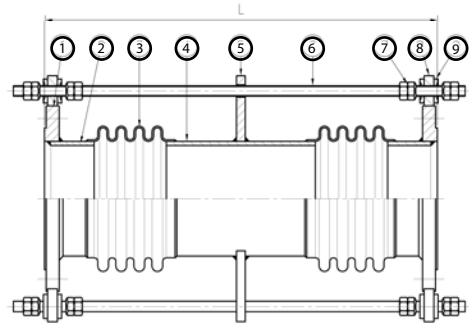

## Feature

**Absorbion for large amount of thermal expansion:**  
 Double Bellows Expansion Joints are employed in piping systems to absorb large amount of differential thermal expansion while and lateral displacement containing the system pressure.

**Maximize the productivity:**  
 Standard design of movement and material maximizes the productivity while the custom design maximizes the suitability for special applications.

**Reliability:**  
 Computer designed bellows element complies with EJMA criteria.

**Quality:**  
 All products are tested before delivery according to relevant code or ISO quality control system.

Item	Qty	Name	Standard Material
1	2	Flange	SS400
2	2	Short Pipe	CS
3	2	Bellows	SUS316L
4	1	Middle Pipe	CS
5	-	Middle Holder	SS400
6	-	Limit Rods	SS400
7	-	Spherical Nut and Nut	SS400
8	-	Thick Holder	SS400
9	-	Conical Seat	SS400

<b>Design Working Pressure</b>	1.02 MPA (10 Kg/cm <sup>2</sup> )
<b>Design Working Temperature</b>	250°C
<b>Applicable Fluid</b>	Water, Hot Water, Oil, Steam, Gas, and Exhaust Air
<b>Axial Movement</b>	25 mm
<b>Lateral Movement</b>	25 mm

Size	Spring Rate (N/mm)		Effective Area (cm <sup>2</sup> )	SJT-7200		SJT-7200-BB	
	Axial	Lateral		L (mm)	Weight (kg)	L (mm)	Weight (kg)
40A	83	2	25	500	7	500	4
50A	95	3	36	500	9	500	5
65A	94	4	51	500	13	500	6
80A	89	5	79	500	17	500	8
100A	116	9	128	550	25	550	14
125A	122	16	187	550	29	550	18
150A	124	21	262	550	36	550	23
200A	124	27	441	600	58	600	36
250A	125	45	665	600	81	600	51
300A	144	83	948	600	109	600	62
350A	145	99	1133	600	138	600	76
400A	138	137	1452	600	170	600	90
450A	147	156	1822	650	204	650	117
500A	182	248	2290	650	270	650	159
600A	221	316	3230	700	373	700	219

## Installation Guide

Nuts are fixed by welding for allowable movement setting  
 Shipping devices (painted yellow) must be removed prior to start-up or testing the system.  
 Please consult us for other material, pressure, temperature and movement designs.  
 Please read the instruction xxxxx before designing and installation.

# SJT8200

**METAL EXPANSION JOINT FOR WATERWORKS PIPING  
UNDERGROUND TYPE**

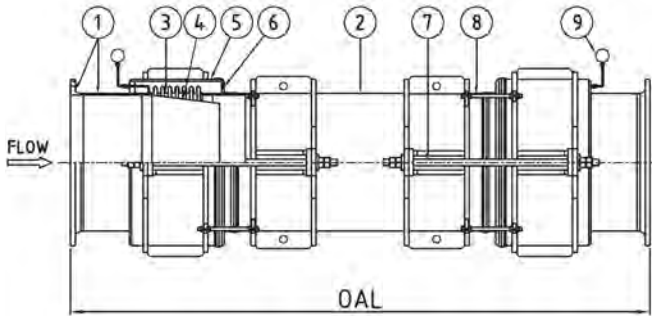

Item	Qty	Name	Standard Material
1	2	Fixed Flange & Pipe	Carbon Steel (SS400)
2	1	Middle Pipe	Carbon Steel (SS400)
3	2	Stainless Steel Bellows	Stainless Steel (SUS316L)
4	2	Inner Sleeve	Stainless Steel (SUS316L)
5	2	Cover Pipe	Carbon Steel (SS400)
6	2	Rubber Soil Shield	Rubber w/synthetic reinforcement
7	2	Tied Rod	Carbon Steel w/H.D. Galv
8	-	Shipping Rod & Holder	SS400
9	2 set	Monitoring pressure gauge	(Optional)

<b>Design Working Pressure</b>	10 bar (ANSI 150)
<b>Design Working Temperature</b>	Ambient
<b>Applicable Fluid</b>	Fresh water

- Shipping devices (*yellow sticker*) must be removed prior to start-up or testing the system.
- Please consult us for other material, temperature and movement designs.

Size mm (inch)	Axial Movement (mm)	The Overall Length (OAL, mm) for the Lateral Movement, Y		
		Y=200 mm	Y=500 mm	Y=800 mm
300A(12")	+50	1800	3200	3600
350A(14")	+50	1800	3200	3800
400A(16")	+50	1800	3200	3800
450A(18")	+50	1900	3200	4000
500A(20")	+50	2000	3500	4000
600A(24")	+50	2100	3500	4500
700A(28")	+50	2100	3500	4500
800A(32")	+50	2200	4000	5000
900A(36")	+50	2300	4000	5400
1000A(40")	+50	2300	4000	5400
1200A(48")	+50	2500	4500	6000
1350A(54")	+50	2600	4500	6000
1400A(56")	+50	2600	4500	6000
1500A(60")	+50	2700	4500	6200
1800A(72")	+50	2900	5000	7000

- Noted: 1) Radiographic test (X-ray) on longitudinal welding and seam is available upon request.  
 2) Material of steel pipe refer to ASTM A283 or JIS G3101 or equivalent.  
 3) Steel pipe surface preparation standard to SSPC-SP10,(Gr 2-1/2).  
 4) All interior and exterior surface of carbon steel or mild steel parts (except stainless steel part) are coated with liquid epoxy coating system (containing no coal tar) conforming to AWWA C210 with minimum thickness 406 microns or otherwise upon request.  
 5) Redundant ply design & monitoring pressure gauge is available upon request.



---

**TOZEN INDUSTRIAL CO., LTD.**

3388/62 18TH FLOOR, SIRINRAT BLDG.,  
RAMA IV RD., BANGKOK 10110 THAILAND  
TEL : (66) 2029-0100  
FAX : (66) 2029-0111  
URL : [www.tozen.co.th](http://www.tozen.co.th)

**TOZEN CORPORATION**

8-4, ASAHI YOSHIKAWA  
SAITAMA 342-008 JAPAN  
TEL : 048-993-1030  
FAX : 048-993-1038