

VIBRATION ISOLATOR

NOISE & VIBRATION CONTROL PRODUCT



Today, most of sophisticated buildings are provided with air conditioning systems and other equipments to create a comfortable working or living environment. However, these mechanical equipments generate vibration and vibration induced noise, which has become a major sources of occupant complaint in modern buildings. The noise and vibration problem is compounded by increasing uses of lighter weight construction and equipments located in penthouses or intermediate level mechanical rooms. It increased structure borne vibration and noise transmission. Not only is the physical vibration in the structure disturbing, but noise which is regenerated by the structural movement may also be heard in other remote sections of the building structure.

frequency, f_n , becomes lower than distributing frequency, f_d , the isolation range is entered when the ratio of f_d/f_n becomes bigger than $\sqrt{2}$.

In Figure 2, the formula expressed the natural frequency of the isolator is a function of isolator deflection. Theoretically, it is desirable to select isolators with a natural frequency as far below the equipment operating speed as possible to achieve the highest degree of vibration control. However, when the ratio approaches 6:1, it takes very large increases in static deflection to reduce isolator natural frequency and further reduce transmission.

VIBRATION TRANSMISSIBILITY CURVE FOR AN ISOLATED SYSTEM

$$f_n = 947 \sqrt{\frac{1}{\text{deflection in mm.}}}$$

(Fig. 2)

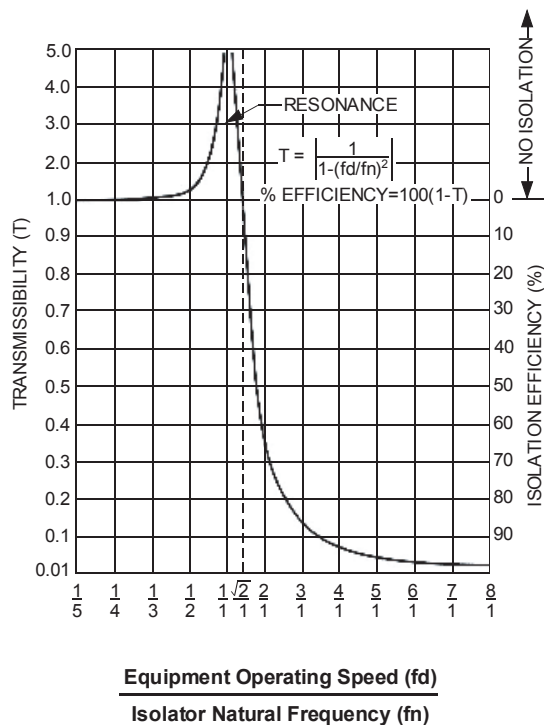

(Fig. 1)

TOZEN vibration and noise control products are designed to isolate or reduce the damaging structure vibration and annoying noise produced by the mechanical equipments. Owing to continuous research and development program, Tozen vibration and noise control products are recognized as a best solution to every day problems and for complex applications requiring optimum vibration and noise control.

Effectiveness of the vibration control, or vibration isolating efficiency is a function of the ratio of the equipment operating frequency, f_d , to isolator natural frequency, f_n . Figure 1 shown a typical vibration transmissibility curve for vibrating equipments supported on isolators. When the $f_d=f_n$, the system resonance occurs, the exciting forces will be amplified rather than reduced. As isolator natural

Theoretical isolation efficiency shown on the transmissibility curve (Fig. 1) assumes the isolators are located on a rigid floor. This rigidity seldom occurs in above grade applications. In practice, considerable building deflection can occur, which may reduce the effectiveness of the vibration isolators. Vibration isolators must be selected to compensate for the floor deflection. Longer spans also allow the structure to be more flexible, permitting the building to be more easily set in operating speeds, equipment horsepower, damping and other factors have been taken into consideration.

By specifying Tozen vibration isolator by type and deflection rather than isolation efficiency, transmissibility, or other theoretical parameters. The consulting engineer can compensate for floor deflection and building resonances by selecting isolators which are satisfactory to provide minimum vibration transmission and which have more deflection than the supporting floor.

When the specifier permits equipment suppliers to provide "appropriate" isolators, which are not manufactured under Tozen or equivalent high standards, a satisfactory job is not ensured, since different brands of isolators may be furnished and no one supplier except Tozen can carry the full responsibility for a building free of vibration and noise as specified.

To apply the information from the Selection Guide, base type, isolator type, and minimum deflection, columns are added to the equipment schedule, and the isolator specifications are incorporated into mechanical specifications for the project. Then, for each piece of mechanical equipment, base type, isolator type and minimum deflection are entered, as tabulated in the Selection Guide.

Selection Guide for Tozen Vibration Isolator

EQUIPMENT TYPE Category & Capacity	GRADE SUPPORTED SLAB			6 METER FLOOR SPAN			9 METER FLOOR SPAN			12 METER FLOOR SPAN			15 METER FLOOR SPAN		
	Base Type	Isolator Type	Min. Deflection	Base Type	Isolator Type	Min. Deflection	Base Type	Isolator Type	Min. Deflection	Base Type	Isolator Type	Min. Deflection	Base Type	Isolator Type	Min. Deflection
Refrigeration Machines															
- Reciprocating Chillers	A	2	6	A	4	20	A	4	40	A	4	65	A	4	65
- Centrifugal Chillers	A	1	6	A	4	20	A	4	40	A	4	65	A	4	65
- Open Centrifugal Chillers	C	1	6	C	4	20	C	4	40	C	4	65	C	4	65
- Absorption Chillers	A	1	6	A	4	20	A	4	40	A	4	65	A	4	65
Air compressors															
- Tank Mounted	A	3	20	A	3	20	A	3	40	A	3	65	A	3	65
- Base Mounted	C	3	20	C	3	20	C	3	40	C	3	65	C	3	65
Pumps-Close coupled															
- Up to 6 kW	B/C	2	6	C	3	20	C	3	20	C	3	20	C	3	20
- 7.5 kW & over															
- Flexible coupled															
- Up to 30 kW	C	3	20	C	3	20	C	3	40	C	3	40	C	3	40
- 37 to 93 kW	C	3	20	C	3	20	C	3	40	C	3	65	C	3	65
- 110 kW & over	C	3	20	C	3	20	C	3	40	C	3	65	C	3	90
Cooling Towers															
- Up to 300 rpm	A	1, 2	6	A	4	65	A	4	90	A	4	90	A	4	90
- 301 to 500 rpm	A	1, 2	6	A	4	65	A	4	65	A	4	65	A	4	90
- 501 rpm & over	A	1, 2	6	A	4	20	A	4	40	A	4	40	A	4	65
Axial, Tubular & Fan heads															
- Up to 550mm dia.	A/B	2	6	A/B	3	20	A/B	3	20	A/B	3	20	A/C	3	40
- 600mm wheel dia. & over															
- Up to 300 rpm	B/C	3	65	C	3	90	C	3	90	C	3	90	C	3	90
- 301 to 500 rpm	B/C	3	20	C	3	40	C	3	65	C	3	65	C	3	65
- 501 rpm & over	B/C	3	20	C	3	40	C	3	40	C	3	40	C	3	65
Centrifugal Fans & Vent Sets															
- Up to 550mm wheel dia.	A/B	2	6	A/B	3	20	A/B	3	20	A/B	3	20	A/C	3	20
- 600mm wheel dia. & over															
- Up to 37 kW															
- Up to 300 rpm	B	3	65	B	3	90	B	3	90	B	3	90	B	3	90
- 301 to 500 rpm	B	3	40	B	3	40	B	3	40	B	3	65	B	3	65
- 501 rpm & over	B	3	20	B	3	20	B	3	20	B	3	40	B	3	65
- 45 kW & up															
- Up to 300 rpm	B/C	3	65	C	3	90	C	3	90	C	3	90	C	3	90
- 301 to 500 rpm	B/C	3	20	C	3	40	C	3	65	C	3	65	C	3	90
- 501 rpm & over	B/C	3	20	C	3	40	C	3	40	C	3	90	C	3	90
Packaged Air Handling Equipments															
- Up to 7.5 kW	A	2	6	A	3	20	A	3	20	A	3	20	A	3	40
- 11 kW & over															
- Up to 500 rpm	A	2	6	A	3	20	A	3	40	A	3	40	A	3	65
- 501 rpm & over	A	2	6	A	3	20	A	3	40	A	3	40	A	3	65

Base Types : A = No base, isolators attached directly to equipment
 B = Structural steel rails or base
 C = Concrete inertia base

Isolator Types : 1 = Rubber pad
 2 = Rubber floor isolator and hanger
 3 = Unhoused floor isolator or hanger
 4 = Restrained spring isolator

PTM-A FLOOR MOUNTING SINGLE SPRING ISOLATOR
PTM-AM HEAVY LOADING MULTIPLE SPRING ISOLATOR

DESCRIPTION : TOZEN Model PTM-A & PTM-AM series isolators are unboxed, spring, vibration isolators, designed for high deflection. The PTM-A employs the use of a single spring element, while the PTM-AM employs multiple spring elements for heavier applications. These laterally stable steel spring isolators are constructed with a leveling device at the top of the isolator and a non-skid acoustical pad at the bottom. Both models are constructed with upper and lower ductile cast iron holding cups to hold the spring element. In addition, PTM-A & PTM-AM have a mounting base plate to allow the isolator to be bolted to a structure and a resilient washer as part of the non-skid acoustical pad. The resilient washer helps prevent the transmission of noise and vibration from the base plate and mounting bolt to the structure.

The design of the spring elements, within the isolators, complies with established standard JIS B2704, for semi-permanent use. To assure lateral stability, the outside diameter of the spring element is greater than 80% of the height of the compressed spring element when at rated load. All the spring elements are designed to provide a minimum of overloading capacity of 50%.

PTM-A & PTM-AM series vibration isolator are available in the standard deflections at 25 mm, and also available in deflections of 50 and 75 mm. Load capacity of the PTM-A isolators range from 25 to 1,400 Kgs (55 to 3080 lbs) and up to 5,600 Kgs (12320 lbs.) for PTM-AM isolators.

Tozen PTM-A & PTM-AM series of spring isolators are highly effective in the control of both high and low frequency vibrations produced by mechanical equipment, such as Reciprocating Air or Refrigeration Compressors, Pumps, Air Conditioning and Air Handling Equipment, Centrifugal and Axial Fans, Internal Combustion Engines and similar types of equipment.

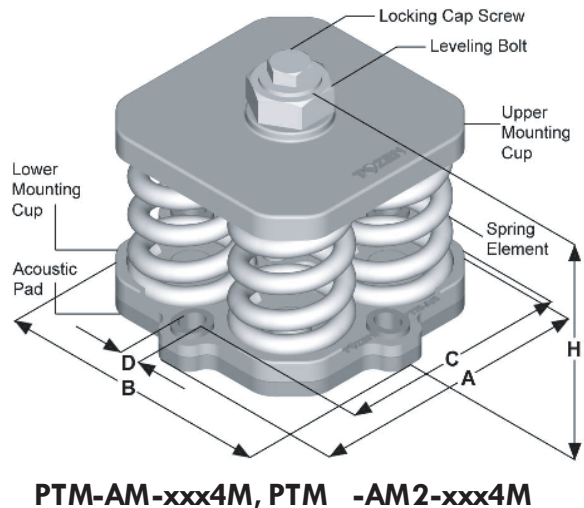
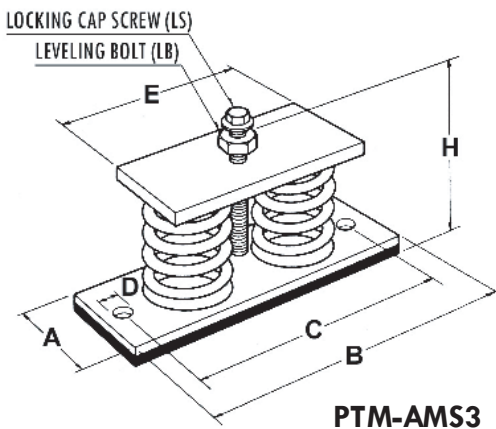
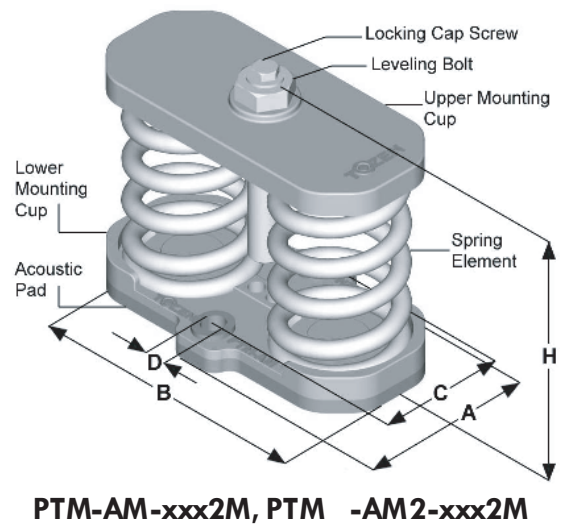
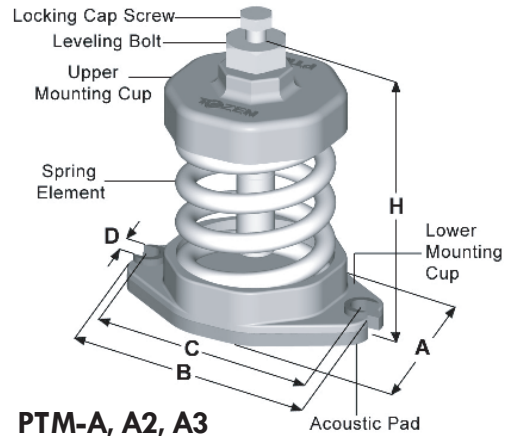

Note : xxx = Rated Capacity
 PTM-AM3 is steel fabricated model.

APPLICATION : PTM-A & PTM-AM series spring isolators are recommended for use in isolating floor mounted sources of noise and vibration located near critical quiet areas.

PTM-A series spring isolators are typically used to reduce the transmission of noise and vibration from low speed mechanical equipment into a building structure.

PTM-A & AM series spring isolators can be used in a wide range of applications involving the isolation of mechanical equipment, such as Reciprocating Air or Refrigeration Compressors, Close Coupled and Base Mounted Pumps, Package Air Handling and Refrigeration Equipment, Centrifugal Fans, Internal Combustion Engines and similar equipment.

SPECIFICATION :

The vibration isolators shall be free standing, with laterally stable steel spring elements, without housings, snubbers or guides. The isolators shall be constructed with the ductile cast iron upper mounting cup and the ductile cast iron lower mounting cup to hold the spring element, and a non-skid acoustical pad is attached under the lower cup. The isolators shall be provided with an adjusting bolt, cap screw and washer in top of the isolator for leveling and attachment to the equipment. The spring elements of the isolator shall have an outside diameter greater than 80% of the height of the compressed spring element at rated load. All spring elements shall be designed to provide a minimum overloading capacity of 50%.

The isolators shall be selected to provide operating static deflection shown on the Vibration Isolation Schedule or as indicated by the project specifications. Isolators shall be color coded or otherwise identified to indicate load capacity.

PTM-A, AM TYPE

25 mm DEFLECTION SINGLE & MULTIPLE SPRING VIBRATION ISOLATOR

MODEL	RATED CAPACITY		SPRING CONSTANT (kg/mm)	SPRING ELEMENT			OPERATING HEIGHT (H)	DIMENSION (mm)				LOCKING CAP SCREW (LS)	LEVELING BOLT (LB)
	(kgs)	(Lbs)		SPRING COLOR	OD (mm)	FREE HEIGHT (mm)		A	B	C	D		
PTM-A-25S	25	55	1.0	WHITE									
PTM-A-35S	35	77	1.4	YELLOW									
PTM-A-50S	50	110	2.0	ORANGE									
PTM-A-80S	80	176	3.2	VIOLET	50	80	120	61	107	89	10	M10x32	M16x70
PTM-A-120S	120	264	4.8	RED									
PTM-A-175S	175	385	7.0	GREY									
PTM-A-225S	225	495	9.0	BROWN									
PTM-A-200	200	440	8.0	VIOLET									
PTM-A-300	300	660	12.0	RED									
PTM-A-450	450	990	18.0	GREEN									
PTM-A-600	600	1320	24.0	GREY	75	100	150	88	136	117	13	M12x43	M22x80
PTM-A-825	825	1815	33.0	BROWN									
PTM-A-1100	1100	2420	44.0	BLUE									
PTM-A-1400	1400	3080	56.0	BLUE+BROWN									
PTM-AM-1652	1650	3630	66.0	BROWN									
PTM-AM-2202	2200	4840	88.0	BLUE	75	100	144	112	198	75	14x18	M12x43	M22x80
PTM-AM-2802	2800	6160	112.0	BLUE+BROWN									
PTM-AM-3304	3300	7260	132.0	BROWN									
PTM-AM-4404	4400	9680	176.0	BLUE	75	100	152	197	197	161	14x18	M16x45	M30x90
PTM-AM-5604	5600	12320	224.0	BLUE+BROWN									

NOTE-1: All springs are laterally stable and suitable for free standing application. (Outside diameter > 80% of deflection height)

NOTE-2: All springs are designed with additional travel to solid at least 50% of rated load.

NOTE-3: Please refer to relevant brochure or our technical division for greater deflection and loading.

PTM-A2, AM2 TYPE

50 mm DEFLECTION SINGLE & MULTIPLE SPRING VIBRATION ISOLATOR

MODEL	RATED CAPACITY		SPRING CONSTANT (kg/mm)	SPRING ELEMENT			OPERATING HEIGHT (H)	DIMENSION (mm)				LOCKING CAP SCREW (LS)	LEVELING BOLT (LB)	
	(kgs)	(Lbs)		SPRING COLOR	OD (mm)	FREE HEIGHT (mm)		A	B	C	D			
PTM-A2-25S	25	55	0.5	WHITE	75	120	170	88	136	117	13	M12x43	M22x80	
PTM-A2-35S	35	77	0.7	YELLOW										
PTM-A2-50S	50	110	1.0	ORANGE										
PTM-A2-80S	80	176	1.6	VIOLET										
PTM-A2-125S	125	275	2.5	RED										
PTM-A2-175S	175	385	3.5	GREY										
PTM-A2-250S	250	550	5.0	BROWN										
PTM-A2-175	175	385	3.5	ORANGE	90	145	195	101	155	130	13	M12x43	M22x115	
PTM-A2-245	245	539	4.9	VIOLET										
PTM-A2-350	350	770	7.0	RED										
PTM-A2-525	525	1155	10.5	GREEN										
PTM-A2-750	750	1650	15.0	GREY										
PTM-A2-1050	1050	2310	21.0	GREY+BROWN										
PTM-AM2-1502	1500	3300	30.0	GREY	90	145	189	130	230	92	14x18	M12x43	M22x80	
PTM-AM2-2102	2100	4620	42.0	GREY+BROWN			196	244	244	203	14x18	M16x45	M30x90	
PTM-AM2-3004	3000	6600	60.0	GREY										
PTM-AM2-4204	4200	9240	84.0	GREY+BROWN										

NOTE-1: All springs are laterally stable and suitable for free standing application. (Outside diameter > 80% of deflection height)

NOTE-2: All springs are designed with additional travel to solid at least 50% of rated load.

NOTE-3: Please refer to relevant brochure or our technical division for greater deflection and loading.

PTM-A3, AMS3 TYPE

75 mm DEFLECTION SINGLE & MULTIPLE SPRING VIBRATION ISOLATOR

MODEL	RATED CAPACITY		SPRING CONSTANT (kg/mm)	SPRING ELEMENT			OPERATING HEIGHT (H)	DIMENSION (mm)				LOCKING CAP SCREW (LS)	LEVELING BOLT (LB)
	(kgs)	(Lbs)		SPRING COLOR	OD (mm)	FREE HEIGHT (mm)		A	B	C	D		
PTM-A3-180S	180	396	2.4	ORANGE	90	170	220	101	155	130	13	M12x43	M22x115
PTM-A3-255S	255	561	3.4	VIOLET									
PTM-A3-375S	375	825	5.0	RED									
PTM-A3-555	555	1221	7.4	GREY	110	190	242	121	181	149	13	M12x43	M22x115
PTM-A3-810	810	1782	10.8	YELLOW									
PTM-A3-1065	1065	2343	14.2	YELLOW+BROWN									
PTM-AMS3-1112	1110	2442	14.8	GREY	110	190	255	125	360	330	16	M12x43	M22x160
PTM-AMS3-1622	1620	3564	21.6	YELLOW									
PTM-AMS3-2132	2130	4686	28.4	YELLOW+BROWN									

PTM-AMS4 TYPE: 100mm deflection model is also available upon request.

NOTE-1: All springs are laterally stable and suitable for free standing application. (Outside diameter > 80% of deflection height)

NOTE-2: All springs are designed with additional travel to solid at least 50% of rated load.

NOTE-3: Please refer to relevant brochure or our technical division for greater deflection and loading

NOTE-4: PTM-AMS is multi spring of carbon steel type

INSTALLATION INSTRUCTION :

- 1) Block or lift up the equipment to a level so that the equipment's leg or base is 5 mm higher than isolator's operating height (see catalogue). If common base & height saving isolator bracket is used, keep 50-mm clearance between the base and floor. Maintain this height until piping installation is completed.
- 2) Locate the spring isolator under the hole in equipment's leg or isolator's bracket. Connect locking cap screw and washer, but do not tighten.
- 3) Transfer the equipment weight to the spring by taking two counter-clockwise turns on each leveling bolt around the unit until springs are compressed just enough to remove the blocks.
- 4) Tighten the locking cap screw to lock the assembly.

REMARKS :

- a) DO NOT install the equipment on the support of a free spring. This will cause an insufficient operating height for the spring isolator when the installation is completed.
- b) Weight of vertical piping and valves must to supported by the suspension hangers or supports.
- c) Install the flexible joint at the end of the installation, following the pre-extension instruction which may specified or suggested by the flexible joint manufacturer.
- d) Bolting down the isolator to the floor, in most cases, is not necessary as the non-slip rubber pad or mounting cup will prevent movement. Where bolting is required, avoid a direct metal contact between bolt and mounting, to prevent transmission of noise; the bolt shank shall be clear in the hole and a rubber washer used under the bolt head. Bolts shall only be tightened a half turn more than hand tight.

PTM-C, CH, CG HOUSED SPRING ISOLATOR

DESCRIPTION : TOZEN PTM-C, PTM-CH and PTM-CG series spring vibration isolators are designed and constructed for high deflection, with laterally stable spring elements and assembled into telescoping cast iron housing. Each cast iron housing is equipped with an 8 mm thick, ribbed, noise absorbing pad that is bonded to the bottom. Each isolator has an internal or external adjusting/leveling bolt as a part of the top assembly. The ribbed, noise absorbing pad has an integrated resilient washer that prevents the transmission of noise and vibration from the contact of the bolt and mounting base plate to the structure. Holes or slots are provided in all of the isolators for bolting the isolator to the structure. Model PTM-C series spring isolators are available in standard deflection of 25 and 50 mm with load capacity from 200 Kgs to 1,400 Kgs (440 to 3080 lbs). Tozen Model PTM-C spring isolators are typically used to isolate vibration produced by mechanical, industrial, or process machinery, where more damping is required and less motion can be tolerated than with free standing spring isolators.

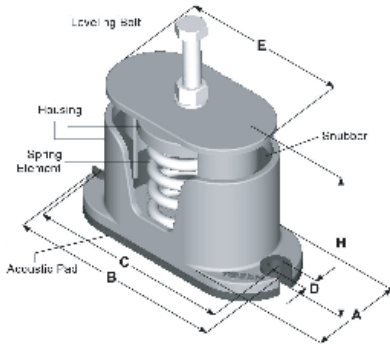

PTM-C, PTM-C2

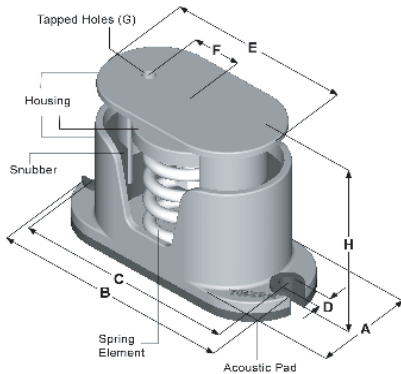

PTM-CH, PTM-CH2

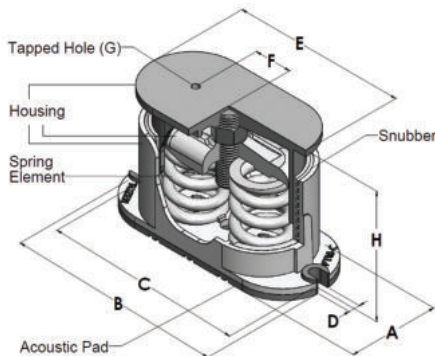

PTM-CH (2M)

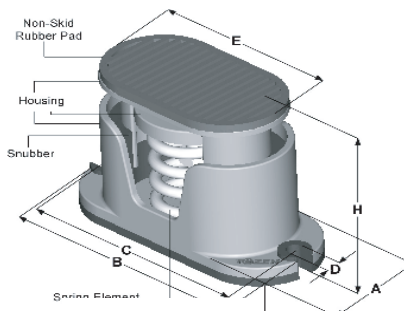

PTM-CG, PTM-CG2

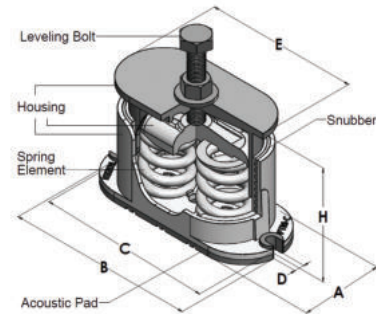

PTM-C (2M)

APPLICATION : TOZEN Model PTM-C spring isolators are used to isolate high and low frequency vibration generated by floor mounted mechanical equipment located in non-critical and semi-critical areas.

Model PTM-C spring isolators are typically used to isolate the vibration produced by light weight mechanical equipment having the lowest operating speed of 1,200 rpm, located on grade supported slabs, or short structural floor spans, or when the isolator to equipment connection is such that a leveling bolt can be extended above the mount and act as a leveling and attachment bolt for the supporting equipment.

Model PTM-CH isolators are available with tapped holes at the top of the loading plate for bolting the isolator to the supporting equipment. An internal leveling device is provided for height adjustments, which is accessible through the side opening by means of an open-end wrench.

Model PTM-CG isolators are available with non-skid rubber pad bonded at the top loading plate to eliminate the need for bolting down the supporting equipment. An internal leveling device is provided for height adjustment, which is accessible through the side opening by means of an open-end wrench.

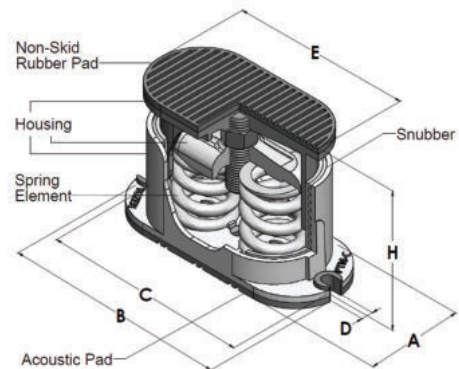

PTM-CG(2M)

SPECIFICATION : The vibration isolators shall be constructed with cast iron housed steel spring elements, a load cap and rubber sponge snubbers. The snubbers shall be designed to stabilize the isolator and prevent metal on metal contact within the top or bottom of the housed section. The top loading plate shall be constructed with a leveling bolt and lock nut.

The housing's bottom shall be bonded to an 8 mm thick, ribbed, rubber pad and shall be slotted or drilled to allow for the bolting of the isolator to the supporting structure.

Outside diameter of the spring elements shall be greater than 80% of the compressed height of the spring element at the rated load. All spring elements shall be designed to provide a minimum 50% overload capacity.

Spring shall be selected to provide operating static deflections shown on the Vibration Isolation Schedule or as indicated on the project specifications. Springs shall be color coded or otherwise identified to indicate load capacity.

Vibration isolators shall be Model PTM-C as manufactured by Tozen Industrial Co.,Ltd.

PTM-C, CH, CG TYPE 25 mm DEFLECTION ANTI-VIBRATION MOUNTING

(mm)

MODEL	RATED CAPACITY		SPRING CONSTANT (Kg/mm)	SPRING COLOR	OPERATING HEIGHT (H)			(A)	(B)	SLOT PITCH (C)	SLOT HOLE (D)	TOP PLATE LENGTH (E)	CH TYPE		C-TYPE LEVELING BOLT (LB)
	(Kgs)	(Lbs)			C TYPE	CH TYPE	CG TYPE						(F)	(G)	
PTM-C-200	200	440	8	VIOLET											
PTM-C-300	300	660	12	RED											
PTM-C-450	450	990	18	GREEN											
PTM-C-600	600	1320	24	GREY	145	162	170	94	216	194	13	162	45	M12	M16
PTM-C-825	825	1815	33	BROWN											
PTM-C-1100	1100	2420	44	BLUE											
PTM-C-1400	1400	3080	56	BLUE+BROWN											
PTM-C-1652	1650	3630	66	BROWN											
PTM-C-2202	2200	4840	88	BLUE	161	185	177	127	297	272	16	242	52.5	M12	M24
PTM-C-2802	2800	6160	112	BLUE+BROWN											

PTM-C2, CH2, CG2 TYPE 50 mm DEFLECTION ANTI-VIBRATION MOUNTING

(mm)

MODEL	RATED CAPACITY		SPRING CONSTANT (Kg/mm)	SPRING COLOR	OPERATING HEIGHT (H)			(A)	(B)	SLOT PITCH (C)	SLOT HOLE (D)	TOP PLATE LENGTH (E)	CH TYPE		C-TYPE LEVELING BOLT (LB)
	(Kgs)	(Lbs)			C2 TYPE	CH2 TYPE	CG2 TYPE						(F)	(G)	
PTM-C2-175	175	385	3.5	ORANGE											
PTM-C2-245	245	539	4.9	VIOLET											
PTM-C2-350	350	770	7	RED											
PTM-C2-525	525	1155	10.5	GREEN	185	202	210	110	254	229	16	195	45	M12	M16
PTM-C2-750	750	1650	15	GREY											
PTM-C2-1050	1050	2310	21	GREY+BROWN											

NOTE-1: All springs are free standing and laterally stable. (Outside diameter do not less than 0.8 times of compressed height.)

NOTE-2: Please refer to relevant brochure of factory for greater deflection and loading.

NOTE-3: PTM-C type External Leveling Bolt (LB) is suitable for maximum 25 mm. bracket or base thickness, please specify for equipment base thicker than 25 mm.

INSTALLATION INSTRUCTION :**A) For PTM-C (External level adjusted) spring isolators**

1. Take out the leveling bolt and lock nut from the top of the isolator.
2. Lift or block up the equipment's leg or isolator bracket to 5mm higher isolator's operating height (see catalogue) and slide the isolators into position. Put the leveling bolt & lock nut back into position.
3. Transfer the equipment weight to the spring by taking two clockwise turns on each leveling bolt around the unit until the springs are compressed just enough to remove blocks.
4. Tighten the lock nut to lock the assembly.

B) For PTM-CH & PTM-CG (Internal level adjusted) spring isolators

1. Check that the internal leveling nut is adjusted up to underside of the top plate.
2. Lift or block up the equipment to 5mm higher than isolator's operating height (see catalogue) and slide the isolators into position and adjust the leveling nut until the top plate is in contact with equipment base. Insert fastening screws (if used) through the equipment base into top of the mounting and tighten.
3. Transfer the equipment weight to the spring by taking two anti-clockwise turns on each leveling bolt around the unit until springs are compressed just enough to remove blocks.

REMARKS :

- a) When the equipment is not subject to rise to the required height, height saving bracket may be attached to the equipment. The height of bracket connection from the bottom of the base shall be 50mm less than the isolator's operating height or to keep a 50mm clearance between the ground and equipment.
- b) DO NOT install the equipment on the support of free spring; it would cause an insufficient operating height for the spring isolator when the installation is completed.
- c) Weight of vertical piping and valves shall be supported by the suspension hangers or other supports.
- d) Install the flexible joint at the completion of the installation, following the pre-extension instructions which may be specified or suggested by the flexible joint manufacturer.
- e) Where bolting is required, avoid a direct metal contact between bolt and mounting, to prevent transmission of acoustical frequencies; the bolt shank shall be clear in the hole and a rubber washer used under the bolt head. Bolts shall only be tightened a half turn more than hand tight.

PTH-S & PTH-S2 SPRING VIBRATION ISOLATING HANGER
PTH-SG SPRING AND RUBBER VIBRATION ISOLATING HANGER

DESCRIPTION : TOZEN PTH-S Series vibration isolating hangers consist of a steel box incorporated with a free standing-laterally stable steel spring with load transfer steel cup and rubber washer. PTH-SG comes in series with noise absorbing hanger rubber properties of both materials. Both design permits installation in the hanger rods or at the ceiling.

The designs of the spring elements are comply to JIS 2704 for a semi-permanent use. To assure stability, outside diameter of the springs do not less than 0.8 times of the compressed height of the spring at rated load. All springs are designed to provide a minimum of 50% overload capacity. Model PTH-S spring hangers are available with 25 mm and 50 mm deflection with standard load capacity from 25 Kgs to 5,600 Kgs, while PTH-SG spring and rubber hangers are available with load capacity up to 825 Kgs. PTH-S and PTH-SG series vibration isolating hangers are recommended for the isolation of vibration produced by suspended mechanical equipment, low speed suspended fans, transformers, ductwork, piping, etc.

APPLICATION : Tozen PTH-S and PTH-SG hangers are used to isolate suspended sources of both audible and inaudible noise and vibration. Suspended mechanical equipment such as in-line fans, cabinet fans, piping and ductwork in close proximity to mechanical equipment, are typical uses of TOZEN PTH-S and PTH-SG hangers. Standard PTH-S and PTH-SG hangers are shipped fully assembled and ready for installation in threaded metal rod suspension systems. Tozen PTH-S and PTH-SG hangers can be provided with labor saving accessories for adaptation to wire or strap suspension system. Both Model PTH-S and PTH-SG hangers may be factory preloaded or provided with positioning plate for ease in erecting piping at a fixed elevation. Higher load capacities, larger deflections and 30 degree ARC capacity available.

SPECIFICATION : Type 1, Vibration isolators for suspended equipment, with minimum static deflection requirement exceeding of 6 mm shall be hangers consisting of a free standing, laterally stable steel spring with load transfer steel cup with rubber washer in series, assembled in a welded steel box. The spring elements shall have an outside diameter not less than 0.8 times of the compressed height of the spring at rated load. All springs shall be designed to provide a minimum of 50% overload capacity. Vibration isolating hangers shall be Model PTH-S as manufactured by Tozen Industrial Co.,Ltd.

Type2, Vibration isolators for suspended equipment with minimum static deflection requirement exceeding 6 mm and where both high and low frequency vibrations are to be isolated, shall be hangers consisting of a laterally stable steel spring in series with a mounted noise absorbing rubber insert, assembled in a welded steel box. The spring elements shall have a outside diameter not less than 0.8 times of the compressed height of the spring at rated load. The combination vibration isolating hangers shall be Model PTH-SG, as manufactured by Tozen Industrial Co., Ltd.

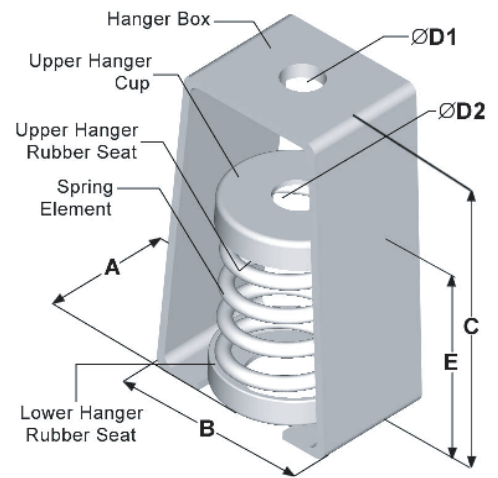

PTH-S-xxx (Capacity 10 - 450)
PTH-S2-xxx (Capacity 25 - 250)

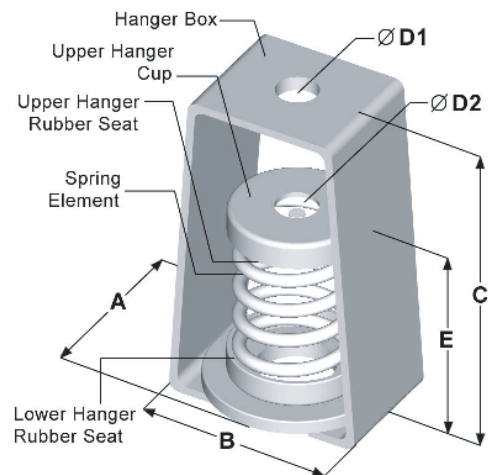

PTH-S-xxx (Capacity 600 - 1100)
PTH-S2-xxx(Capacity 245 - 750)

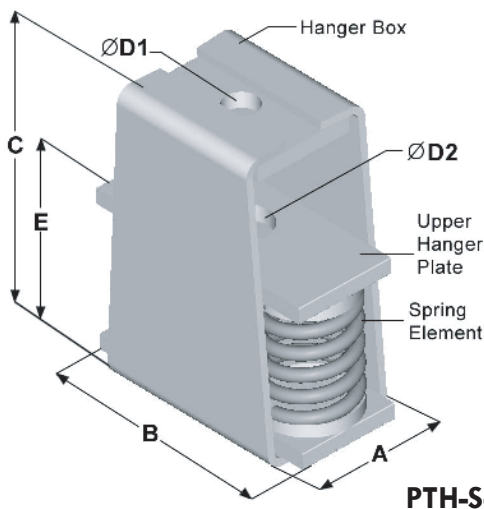

PTH-S-xxx2

Note : xxx = Rated Capacity

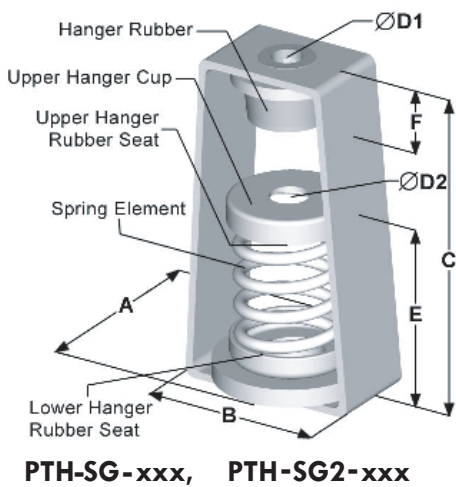
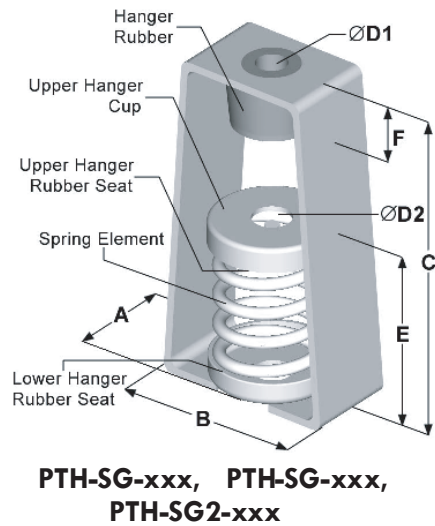
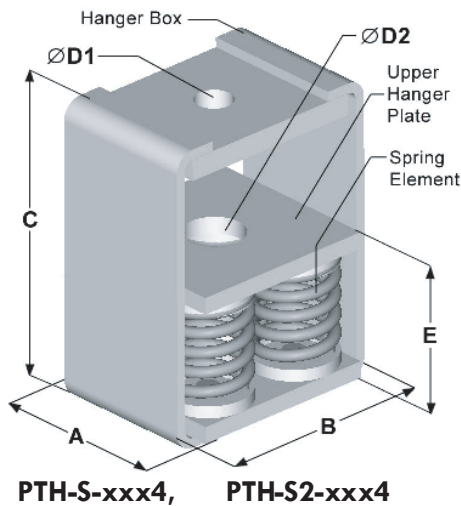

INSTALLATION INSTRUCTION :

- 1) Consider the height and location of the hanger and prepare the upper and lower hanging rod(bolt) in same proper length.
- 2) Attach the upper hanging rod(bolt) to the ceiling.
- 3) Connect the lower hanging rod (bolt) to the hanger. Pre-compress the hanger spring element (Approx. 10 mm) by tighten a restrain nut and washer at the bottom of the hanger.
- 4) Attach the hanger to the upper hanging rod(bolt).
- 5) Attach the hanging rod(bolt) to the pipe, duct or equipment bracket.
- 6) Install all other hangers by repeating instruction 1-5.
- 7) After the pipe or equipment is filled with water, release the restraint nut. Leveling adjust the hanger by the nut at the top of the element to obtain even level installation.
- 8) Final check the spring hanger in a proper deflection and don't install the hanging rod(bolt) in a inclined position.

PTH-S, PTH-S2, PTH-SG

MODEL	RATED CAPACITY		SPRING CONSTANT (Kg/mm)	SPRING COLOR	DIMENSION (mm)						
	(Kgs)	(Lbs)			A	B	C	D1	D2	E	F
PTH-S TYPE 25 MM DEFLECTION											
PTH-S-10	10	22	0.4	GREEN	58	85	145	13	15	92	-
PTH-S-15	15	33	0.6	BLUE							
PTH-S-25	25	55	1	WHITE							
PTH-S-35	35	77	1.4	YELLOW							
PTH-S-50	50	110	2	ORANGE							
PTH-S-80	80	176	3.2	VIOLET	58	85	145	15	15	92	-
PTH-S-120	120	264	4.8	RED							
PTH-S-175	175	385	7	GREY							
PTH-S-225	225	495	9	BROWN	84	120	180	17	18	115	-
PTH-S-300	300	660	12	RED							
PTH-S-450	450	990	18	GREEN							
PTH-S-600	600	1320	24	GREY							
PTH-S-825	825	1815	33	BROWN							
PTH-S-1100	1100	2420	44	BLUE	105	125	200	25	18	123	-
PTH-S-1202	1200	2640	48	GREY							
PTH-S-1652	1650	3630	66	BROWN							
PTH-S-2202	2200	4840	88	BLUE							
PTH-S-2802	2800	6160	112	BLUE+BROWN	124	225	278	30	30	146	-
PTH-S-3304	3300	7260	132	BROWN							
PTH-S-3604	3600	7920	144	BROWN+GREY							
PTH-S-4404	4400	9680	176	BLUE							
PTH-S-5604	5600	12320	224	BLUE+BROWN	195	235	300	36	36	148	-
PTH-S-4404	4400	9680	176	BLUE							

PTH-S, PTH-S2, PTH-SG (continued)

MODEL	RATED CAPACITY		SPRING CONSTANT (Kg/mm)	SPRING COLOR	DIMENSION (mm)						
	(Kgs)	(Lbs)			A	B	C	D1	D2	E	F
PTH-S2 TYPE 50 MM DEFLECTION											
PTH-S2-25	25	55	0.5	WHITE	84	120	210	15	18	135	-
PTH-S2-35	35	77	0.7	YELLOW							
PTH-S2-50	50	110	1	ORANGE							
PTH-S2-80	80	176	1.6	VIOLET							
PTH-S2-125	125	275	2.5	RED							
PTH-S2-175	175	385	3.5	GREY							
PTH-S2-250	250	550	5	BROWN							
PTH-S2-350	350	770	7	RED	105	140	255	21	24	168	-
PTH-S2-525	525	1155	10.5	GREEN							
PTH-S2-750	750	1650	15	GREY							
PTH-S2-1052	1050	2310	21	GREEN	146	260	325	30	30	190	-
PTH-S2-1502	1500	3300	30	GREY							
PTH-S2-2102	2100	4620	42	GREY+BROWN							
PTH-S2-3004	3000	6600	60	GREY	222	260	325	52	38	194	-
PTH-S2-4204	4200	9240	84	GREY+BROWN							
PTH-SG TYPE 25 MM DEFLECTION											
PTH-SG-25	25	55	1.0	WHITE	58	85	180	16	15	92	31
PTH-SG-35	35	77	1.4	YELLOW							
PTH-SG-50	50	110	2.0	ORANGE							
PTH-SG-80	80	176	3.2	VIOLET							
PTH-SG-120	120	264	4.8	RED							
PTH-SG-175	175	385	7.0	GREY							
PTH-SG-200	200	440	8.0	VIOLET	84	130	220	18	18	115	44
PTH-SG-300	300	660	12	RED							
PTH-SG-450	450	990	18	GREEN							
PTH-SG-600	600	1320	24	GREY	120	170	270	20	18	124	50
PTH-SG-825	825	1815	33	BROWN							
PTH-SG2 TYPE 50 MM DEFLECTION											
PTH-SG2-25	25	55	0.5	WHITE	84	140	235	16	18	135	32.5
PTH-SG2-35	35	77	0.7	YELLOW							
PTH-SG2-50	50	110	1	ORANGE							
PTH-SG2-80	80	176	1.6	VIOLET							
PTH-SG2-125	125	275	2.5	RED							
PTH-SG2-175	175	385	3.5	ORANGE							
PTH-SG2-245	245	539	4.9	VIOLET							
PTH-SG2-350	350	770	7	RED							
PTH-SG2-525	525	1155	10.5	GREEN	120	180	310	20	24	168	50
PTH-SG2-750	750	1650	15	GREY							

NOTE-1: All springs have an minimum additional travel to solid equal to 50% of rated load.
 NOTE-2: Please refer to relevant brochure or consult factory for greater deflection and loading.
 NOTE-3: Spring constant applies to spring only.
 NOTE-4: Please consult factory for pre-compressed model and 30 degree arc capacity.

PTH-G VIBRATION ISOLATING RUBBER HANGER

DESCRIPTION : TOZEN PTH-G vibration isolating rubber hangers are designed to reduce the transmission of vibration and noise produced by suspended equipment, piping and ductwork. PTH-G hangers incorporated with a noise absorbing rubber insert with cast-in load transfer plate at the top and bottom, assembled into a steel box. Ultimate design of PTH-G hanger rubbers allows greater deflection without accelerating deterioration. PTH-G hangers are available in deflection maximum up to 6 mm with capacities from 25 Kgs to 450 Kgs. PTH-G rubber hangers may be selected where first cost must be minimized. MODEL PTH-G is recommended for the isolation of vibration produced by suspended mechanical equipment, axial and exhausts fans, ductwork, piping, etc. Double deflection model PTH-GG adds another rubber element at the top of the hanger box.

APPLICATION : TOZEN PTH-G vibration-isolating hangers are used to isolate suspended sources of audible frequency vibration, or isolation of noise in piping and ductwork systems. Model PTH-G hangers are shipped fully assembled and ready for installation in threaded rod suspended systems. Model PTH-G hangers can be provided with labor saving accessories for adaptation to wire or strap suspension systems.

SPECIFICATION : Vibration isolators for suspended equipment, piping and ductwork with maximum static deflection requirements under operation load conditions not exceeding 6 mm shall be hangers consisting of a neoprene or synthetic rubber noise absorbing insert encased in a welded steel box.

The rubber insert shall be moulded from oil resistant compounds with cast in load transfer plate at the top and bottom, shall be color-coded or otherwise identified to indicate load capacity.

Vibration isolating rubber hanger assembly shall be Model PTH-G, as manufactured by Tozen Industrial Co., Ltd.

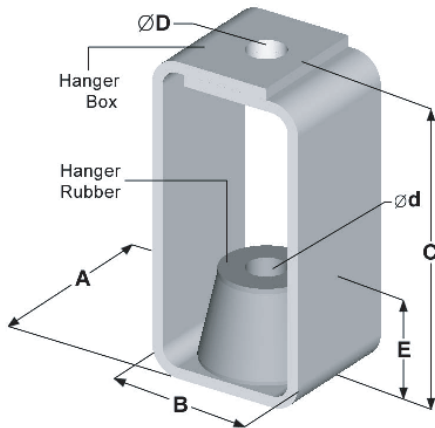

PTH-G-25, 35, 50

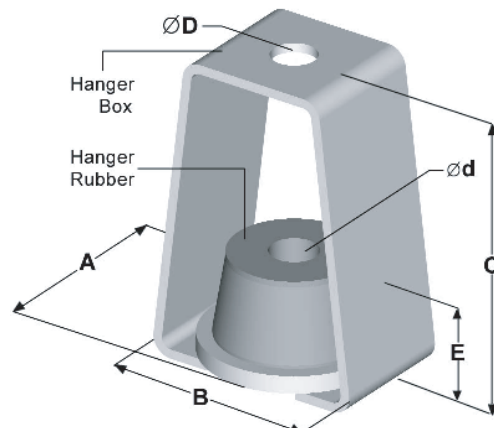

PTH-G-80, 120, 150, 200, 300, 450

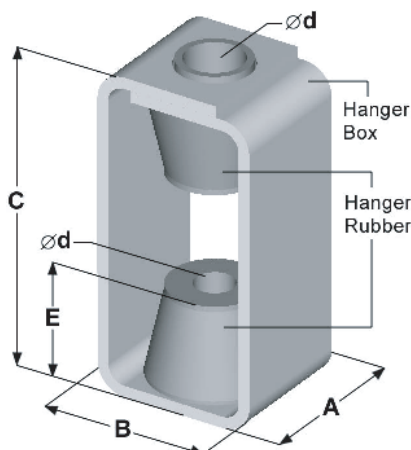

PTH -GG-25, 35, 50

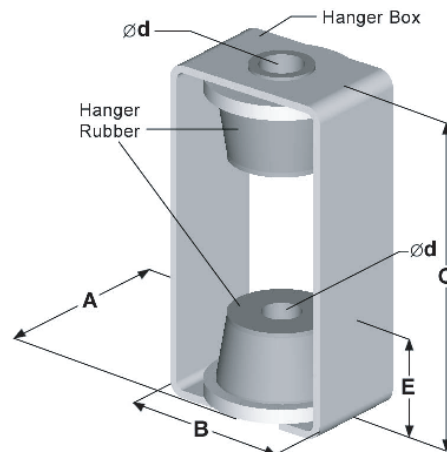

PTH-GG-80, 120, 150, 200, 300, 450

PTH-G, PTH-GG RUBBER HANGER

(mm)

MODEL	DESIGN LOADING		RUBBER COLOR CODE	MAXIMUM STATIC DEFL.	DURA-METER	A	B	C		d		D	E
	(Kgs)	(Lbs)						PTH-G	PTH-GG	PTH-G	PTH-GG	PTH-G	
PTH-G-25	25	55	WHITE	4	40	37	45	90	115	11	11	11	28
PTH-G-35	35	77	YELLOW		50								
PTH-G-50	50	110	ORANGE		55								
PTH-G-80	80	176	PINK	5	40	60	75	105	140	16	16	15	37
PTH-G-120	120	264	RED		50								
PTH-G-150	150	330	ORANGE		55								
PTH-G-200	200	440	PINK	6	40	85	103	132	195	18	18	18	50
PTH-G-300	300	660	RED		50								
PTH-G-450	450	990	GREEN		55								

NOTE-1: Hanger elements have similar straight line deflection curve.

NOTE-2: Please refer to relevant brochure or consult factory for wire or strap suspension systems.